



Series MT Mill-Type Hydraulic Cylinders

- High-Tech Duralon® Rod Bearing
- State-of-the-Art Rod and Piston Sealing System
- Heavy-Duty Piston-to-Rod Connection
- 2,000 PSI Pressure Ratings
- 2.00" – 16.00" Standard Bore Sizes
- 7 Mounting Styles

SERIES MT MILL-TYPE CYLINDERS

CONTENTS



	Page
SERIES MT FEATURES	184
HOW TO ORDER	219
MOUNTING STYLES	
MP1 Fixed Double Ear Clevis Mount	190
MP3 Fixed Single Ear Clevis Mount	192
MPU3 Spherical Bearing Mount	194
MT4 Intermediate Fixed Trunnion Mount	196
ME5 Head Flange Mount	198
ME6 Cap Flange Mount	200
MS7 End Lugs Mount	202
TECHNICAL INFORMATION	
Port Location and Size	204
Hydraulic Force Data	205
Stroke Limitation Data	206
Stop Tube Data	207
MOUNTING ACCESSORIES	208
ELECTRONIC & ELECTRICAL CONTROLS	
Proximity Switches	212
Electronic Feedback Device	213
INSTALLATION, OPERATION AND MAINTENANCE INFORMATION	
Fastener Torques	214
Seal Kits	215
Cylinder Weights	215
Parts List	216
OTHER ACCESSORIES	
Rod Boots	218
Air Bleeds	218

HANNA
cylinders

Series MT Mill-Type Extra-Heavy-Duty Hydraulic Cylinders

Hanna's Series MT Mill-Type Hydraulic Cylinders are designed and built for heavy-duty industrial applications that demand high performance, precision tolerances and extra ruggedness.

Designed for specifying engineers, this catalog presents full details about the Series MT's latest technology design features, complete dimensional drawings, technical application information, options and accessories, plus installation, operation and maintenance data. Clear and concise ordering information facilitates proper cylinder selection for specific applications and operating conditions.

Cylinder Design and Construction

The Series MT product line has been truly value-engineered from the ground up. During the design stage, each and every cylinder component was thoroughly analyzed and tested. Individual component design and material selection were evaluated on the basis of performance, longevity, fatigue resistance, ease of servicing, and cost.

Proven technologies were applied in critical areas such as seals and bearings. For instance, Hanna's unique, non-metallic Duralon rod bearing, and our glass-filled Teflon, O-ring energized piston seal with bronze-filled bearing strips, combine to eliminate metal-to-metal contact at bearing surfaces. This assures extremely low friction and long service life. In addition, it makes Series MT cylinders the most suitable units available for high pressure applications requiring ruggedness, precision, zero leakage and day-in, day-out performance.

Design Flexibility

Series MT cylinders offer maximum flexibility for machine design. They are available in seven standard mounting styles, and 12 standard bore sizes from 2.00" through 16.00". 14 standard rod sizes from 1.00" through 8.00" are also offered, with a minimum of two to a maximum of six rod sizes for each bore size.

This wide selection of standard rod and bore diameters means you can more accurately and economically size the cylinder to meet specific application requirements. Optional piston and rod seal materials and configurations also are available to further increase your design flexibility.

In addition, Hanna offers a wide range of options and accessories to enhance the performance of MT cylinders. Included are proximity switches and, for the ultimate in precision control, our Closed Loop Electronic Feedback device.

Custom Capabilities

If your needs cannot be met by the standard units presented in this catalog, be assured that Hanna has significant "Beyond-the-Catalog" capabilities. We can custom-design and manufacture MT cylinders to meet virtually any requirement—including greater pressures, larger bore sizes through 30", larger rod sizes, custom mountings and special seals for specific applications. In addition, metric cylinders can be designed and manufactured to meet customer requirements.



If you involve us during the design phase of your project, you'll find our problem-solving orientation can provide creative, cost-effective solutions to the most difficult cylinder application problems.

The Company Behind the Cylinders

For more than 85 years, Hanna Corporation has earned its reputation as a major manufacturer of premium quality, industrial grade cylinders. With our Series MT, our Series RT Rotating cylinders, our heavy-duty N.F.P.A. tie-rod type air and hydraulic cylinders, plus custom-welded cylinders manufactured by our T.J. Brooks Division, **Hanna offers a single source for virtually any heavy-duty cylinder requirement.** Add to this the responsive sales and service support from the factory and from our highly qualified distributor organization, and you are assured of getting the right cylinder for your application—on time and at a competitive price.

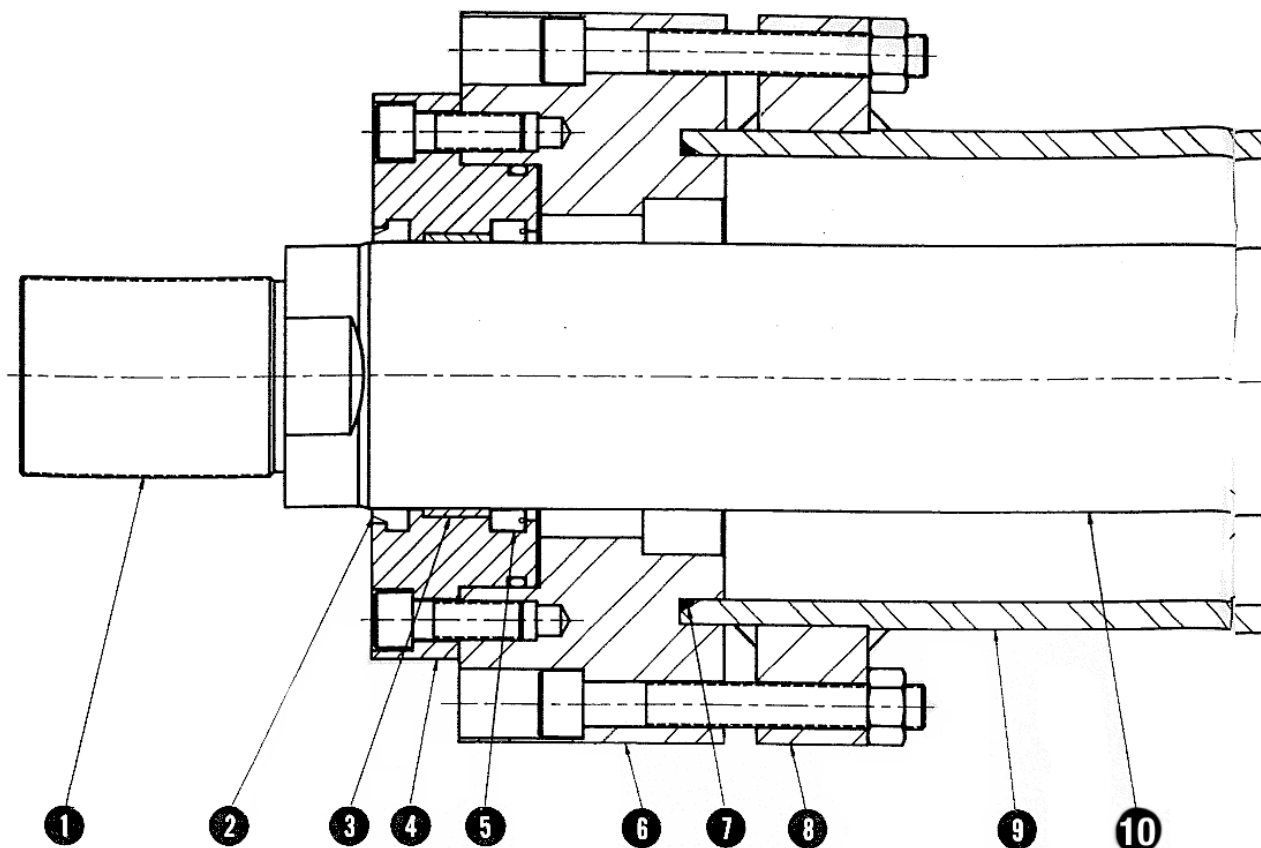

Series MT Features

1. Piston Rod End

Integral thread construction, precision-machined for close concentricity. Studded rod ends and metric threads are available.

2. Rod Wiper

The first line of defense in preventing ingestion of dust, dirt or other contaminants into the cylinder. The snap-in wiper that comes standard on Series MT cylinders is made of extremely durable polyurethane. A heavy wiper lip ensures that contact is always maintained with the surface of the rod to effectively remove dirt, mud, etc. The outside diameter has a sealed outer lip to prevent moisture from entering the groove. Molded ribs on the inside diameter add stability and prevent pressure traps. Metallic rod wiper is optionally available.

3. Duralon Rod Bearing

Hanna's high-tech Duralon Rod Bearing is designed to perform under poorly lubricated, high-load conditions. The exact combination of woven Teflon and Dacron, plus the fiberglass structural shell, increases load-carrying capabilities and eliminates "cold-flow" associated with Teflon. Duralon bearings are capable of sustaining much higher compressive loads than other materials commonly used for bearings, have an extremely low coefficient of friction, and require no lubrication to the bearing surface.

4. Rod Bearing Cartridge

One-piece, machined ductile iron with integral flange. Precision piloted and held to extremely close concentricity to cylinder bore. Flange has two tapped holes to facilitate easy removal for rod packing replacement.

5. Polyurethane Rod Seal

Series MT cylinders incorporate the industry's heaviest cross-section polyurethane U-cup piston rod seal, assuring zero leakage and outstanding wear resistance. Viton Poly-Pak U-cup is available for use with non-petroleum based fluids or for higher temperature service. Multiple-lip Buna rod seal is also available.

6. Steel Heads

High strength steel heads are precision machined to assure accurate alignment and close concentricity between piston, tube, piston rod and rod bearing.

7. Tube Seal

Tube ends are piloted to end caps and fitted with Buna-N O-ring seals. Viton seals are available for use with non-petroleum based fluids, or for higher temperature service.

8. Welded Retaining Flanges

Precision machined and permanently welded for extra ruggedness. End caps are retained to flanges with high-

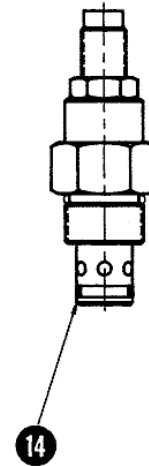
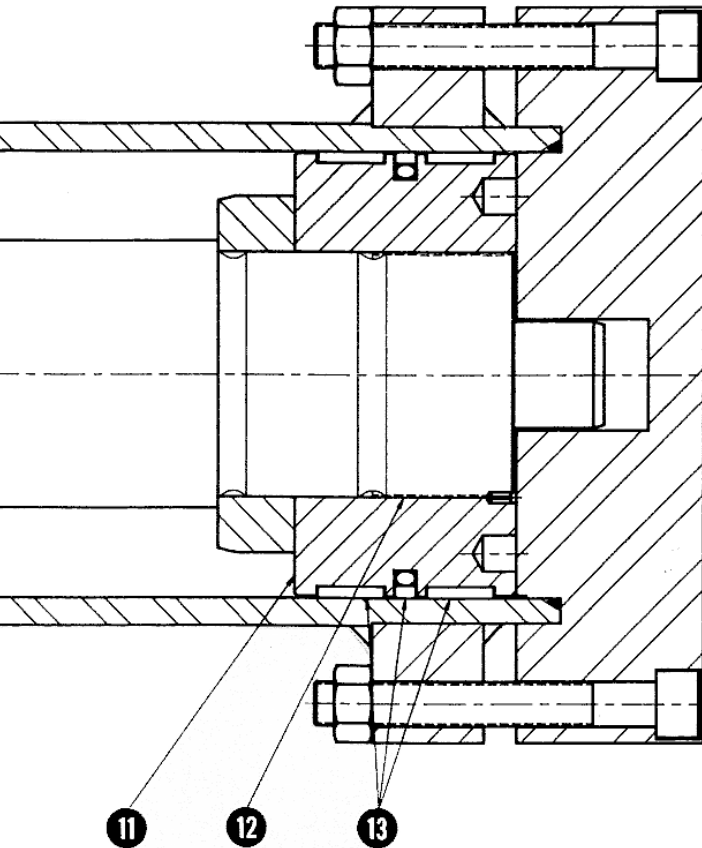

alloy, heat-treated through bolts, counter-bored into the caps, and torqued to flanges with SAE Grade 8 lock nuts. Bolts provide minimum yield strength of 150,000 p.s.i.

9. Heavy Wall Tubing

Heavy wall tubing is precision honed or skived, and then polished to 16 to 20 Rms. This process provides excellent corrosion resistance and an ideal surface to seal against. The result is enhanced piston seal longevity.

10. Piston Rod

Hanna's piston rods are machined to a close tolerance with minimum stock removal to maximize shank size and reduce stress. Relief grooves are machined in areas of high stress to guard against fatigue failure. The rods provide 100,000 p.s.i. minimum yield strength in diameters up to 3.50"; 59,000 p.s.i. average yield strength in 4.00" diameters and above. All sizes are hard chrome plated for scratch and corrosion resistance. To maximize seal and bearing life, plated surface is polished to a 6-8 micro-inch finish.

11. Piston

One-piece piston of high impact-resistant ductile iron threaded to piston rod, and furnished with breakaway spirals on each side. Bronze piston with U-cup seals is available as an extra-cost option.

12. Piston-to-Rod Connection

Piston rods are piloted to the piston to ensure concentricity, then bonded by an anaerobic adhesive, torqued and pinned. This procedure virtually eliminates the possibility of the piston backing off the piston rod.

13. Piston Sealing System

Hanna's glass-filled Teflon, O-ring energized piston seal provides a positive seal without problems such as rollover or extrusion that are associated with U-cup type seals. Glass-filled Nylon wear rings provide non-metallic bearing points on the piston, assuring long life and extremely low friction, while increasing bearing load characteristics.

14. Cushion Adjustment Cartridge

Available as an option on 4.00" bore sizes and above. Ball check and flow control needle adjustment are incorporated into a single cartridge. The needle is always restrained under full adjustment, and provides a wide range of cushion adjustments with minimal restrictions on return stroke.

High-Tech Duralon Rod Bearing

The high-tech Duralon rod bearing is supplied as standard on all Hanna Series MT Mill-Type Cylinders. A traditional bronze bearing is also available as an option.

Hanna strongly recommends the Duralon bearing, which has proven to be superior to all other bearing materials in countless cylinder applications. Here's why:

The useful life of any hydraulic cylinder is determined by the performance of the piston rod bearing. It is responsible for true alignment of the piston rod to the cylinder bore, and must carry the forces generated by both external and internally-generated eccentric loads.

Traditional bronze or cast iron bearings require constant lubrication to help minimize friction and resultant wear. Once the cylinder rod bearings begin to wear, the piston moves off true center of the cylinder bore, thus shortening cylinder life. Additionally, the wear pattern accelerates, causing deterioration in the piston rod wiper, letting contaminants into the cylinder and in the piston rod seal, thereby causing fluid leakage.

Hanna Corporation has solved this critical design problem with the unique, non-metallic Duralon bearing. An exact combination of woven Teflon® and Dacron® fibers bonded to a fiberglass shell, Duralon bearings are capable of sustaining much higher compressive loads than either bronze or cast iron. In addition, Duralon bearings have an extremely low coefficient of friction, and require no lubrication to the bearing surface.

As a result, cylinders with Duralon bearings are ideal for use in heavy-duty applications, and servo systems requiring minimal actuator friction. Because of the low coefficient of friction, very little heat gen-



**Duralon Rod Bearing
in steel cartridge.**



Optional Bronze Bearing.

eration occurs, thereby prolonging both bearing and seal life.

Duralon bearings are compatible with most known fluids, including water, water glycols, standard petroleum-based fluids, phosphate esters and water/oil, oil/water fluids. They can operate in environments ranging from -65° F to +325° F.

DURALON VS. COMPETITIVE BEARING MATERIALS

COMPARISON OF NON-LUBRICATED BEARINGS AND THEIR OPERATING LIMITS		LOAD CAPACITY (PSI)
Porous Bronze	MOST CYLINDER MANUFACTURERS	4500
Porous Iron		8000
Reinforced Teflon®		2500
Duralon Bearing*		60,000

*Not to be used for design purposes.

Duralon is a Trademark of Rexnord, Inc.
Nylon, Teflon and Dacron are Trademarks of DuPont Company.

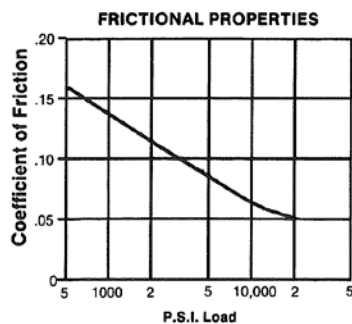

The low friction characteristic of the Duralon bearing is due to the Teflon fabric liner. Increased loading, at constant speed, results in a marked decrease in the coefficient of friction.

COMPARISON OF FRICTION PROPERTIES OF JOURNAL BEARING MATERIALS		
	COEFFICIENT	SLIP STICK
Steel-on-Steel50	Yes
Bronze-on-Steel35	Yes
Aluminum		
Bronze-on-Steel45	Yes
Sintered Bronze-on-Steel (Mineral Oil)13	No
Bronze-on-Steel (Mineral Oil)16	No
Copper Film Deposited on Steel30	Yes
Teflon®-on-Steel04	No
Duralon®-on-Steel05-.16	No

Extra-Rugged Polyurethane Rod Seal

POLYURETHANE ROD SEAL ADVANTAGES

- Extremely high durometer (90)
- Extra-wide cross section
- Broad temperature range
- Compatible with most fluids
- Line contact minimizes friction

Series MT cylinders incorporate the industry's heaviest cross-section polyurethane U-cup piston rod seal. As a seal material, polyurethane is acknowledged to be the toughest, most abrasion-resistant compound available.

The abrasion and wear resistance thus associated with polyurethane, along with the pressure and wear compensating U-cup design, produces a seal that's unmatched for long life and zero-leakage performance.

A second lip further enhances seal life by acting as a wiper to prevent dirt and other contaminants from reaching the primary lip. The second lip also serves as a back-up to the primary lip.

In addition, the heavy cross-section of the polyurethane material produces a seal with outstanding stability in high pressure applications. This stability prevents extrusion and rollover common with small cross section designs.

Furthermore, recent advances in polymer technology have expanded the compatibility of polyurethane seals with most water additive fluids. Viton Poly-Pak seal option is available as well.



Standard Polyurethane Rod Seal
(Code 1)



Optional Poly-Pak Viton U-Cup Seal
(Code 3)

State-of-the-Art Piston Sealing System

STANDARD PISTON SEAL ADVANTAGES

- Positive Sealing
- No rollover or extrusion
- Extremely low friction
- Long service life

The unique, standard piston sealing system on Series MT cylinders combines the sealing capability of U-cups with the longevity of cast iron rings.

The glass-filled Teflon, O-ring energized seal provides positive sealing without problems such as rollover or extrusion that are associated with U-cup type seals.

In addition, two bronze-filled bearing strips provide non-metallic bearing points on the piston, assuring long life and extremely low friction. Located on each side of the seal, the wear strips also wipe the cylinder tube in both directions of piston travel, further extending seal life. These wear strips are capable of withstanding high side loads, and thus prevent galling of the tube, catastrophic cylinder failure, and subsequent damage to valves and other hydraulic system components. They virtually never need to be replaced.

The piston seal has no slip stick and minimal friction. It is ideal for servo-type conditions as well as high water based service.

If you are using a zero-leak check valve circuit, however, it may require the use of optional zero-drift U-cup seals to maintain absolute position. The miniscule by-pass with our standard seal may result in some very minor drift. Both Poly-Pak and Viton U-cups seals are available.



Standard glass-filled Teflon, O-ring energized piston seal with two bronze-filled bearing strips—installed on a ductile iron piston. (Code G)



Optional bronze piston with two Poly-Pak U-cup seals. Viton U-cup seals also available. (Code A)

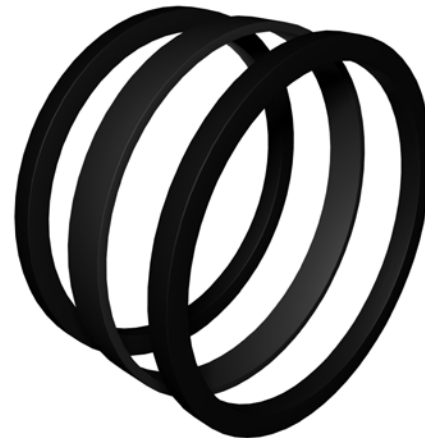
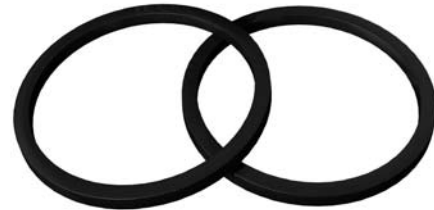

Optional Poly-Pak U-cup seals (2) with one bronze-filled bearing strip—installed on a ductile iron piston. Viton U-cup seals also available (Code B)

SERIES MT 2.00"-16.00" Bores MP1 Fixed Double Ear Clevis Mount

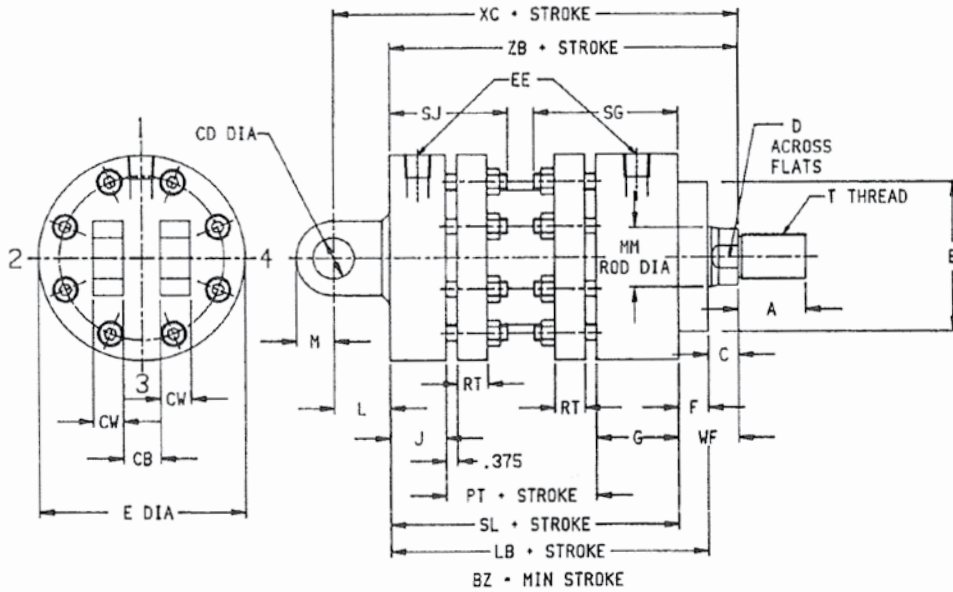

These Dimensions are Constant Regardless of Rod Diameter

BORE	B	BZ	C	CB +.016 +.047	CD +.003 +.005	CW	E	EE		F	G	J	L	LB	M	PT
								SAE STRAIGHT THREAD	NPTF*							
2.00	3.25	1.38	0.81	1.00	0.750	0.75	4.12	#8 (.750-16)	0.50	1.00	2.25	1.38	1.31	6.00	0.75	1.38
3.00	4.50	1.75	0.88	1.25	1.250	0.88	5.38	#12 (1.062-12)	0.75	1.12	2.62	1.75	1.62	7.25	1.12	1.75
4.00	5.00	2.38	1.00	1.25	1.375	1.00	6.88	#12 (1.062-12)	0.75	1.00	2.75	1.88	1.88	7.62	1.25	2.00
5.00	6.38	2.88	1.00	1.25	1.500	1.25	8.25	#12 (1.062-12)	0.75	1.00	3.00	2.12	2.50	8.62	1.38	2.50
6.00	7.38	3.25	1.00	1.50	1.750	1.50	9.62	#16 (1.312-12)	1.00	1.25	3.25	2.25	3.12	9.62	1.62	2.88
7.00	8.25	3.38	1.00	3.00	2.000	1.50	10.75	#16 (1.312-12)	1.00	1.25	3.25	2.25	3.12	9.75	1.62	3.00
8.00	9.75	3.25	1.12	3.00	2.000	1.50	12.38	#20 (1.625-12)	1.25	1.43	3.62	2.50	3.62	11.06	1.88	3.50
9.00	9.75	3.25	1.12	3.00	2.000	1.50	13.38	#20 (1.625-12)	1.25	1.43	3.62	2.50	3.62	11.31	1.88	3.75
10.00	10.75	3.25	1.00	3.50	2.500	1.75	15.50	#24 (1.875-12)	1.50	1.43	4.25	3.12	4.06	13.56	2.38	4.75
12.00	10.75	3.25	1.12	4.50	3.000	2.25	18.75	#24 (1.875-12)	1.50	1.43	4.50	3.62	4.43	15.19	2.88	5.62
14.00	12.00	4.00	1.00	5.00	3.500	2.50	21.50	#32 (2.500-12)	2.00	2.00	5.00	4.25	5.19	17.00	3.38	5.75
16.00	12.00	3.00	2.25	6.00	4.250	3.00	23.62	#32 (2.500-12)	2.00	2.00	6.00	5.00	5.00	19.00	4.00	6.00

*NPTF ports will be furnished unless SAE straight thread ports are specified.
Optional SAE 4-Bolt Flange Ports may be specified—Flange furnished by customer.

BORE	RT	SG	SJ	SL	WF	XC	ZB
2.00	0.50	3.47	2.59	5.00	1.81	8.12	6.81
3.00	0.75	4.22	3.34	6.12	2.00	9.75	8.12
4.00	1.00	4.78	3.91	6.62	2.00	10.50	8.62
5.00	1.25	5.41	4.53	7.62	2.00	12.12	9.62
6.00	1.62	6.19	5.19	8.38	2.25	13.75	10.62
7.00	1.75	6.69	5.69	8.50	2.25	13.88	10.75
8.00	1.88	6.81	5.69	9.62	2.56	15.81	12.19
9.00	2.00	6.81	5.69	9.88	2.56	16.06	12.43
10.00	2.38	7.91	6.78	12.12	2.43	18.62	14.56
12.00	2.75	8.78	7.91	13.75	2.56	20.75	16.31
14.00	3.25	9.66	8.91	15.00	3.00	23.19	18.00
16.00	3.75	10.03	9.03	17.00	4.25	26.25	21.25

NOTE: Dimensions are nominal except where specifically toleranced. Tolerances on "Plus Stroke" dimensions will vary slightly from dimensions shown due to manufacturing tolerances and tube compression.

NOTE: Pivot Pin included.

STANDARD ROD END STYLES

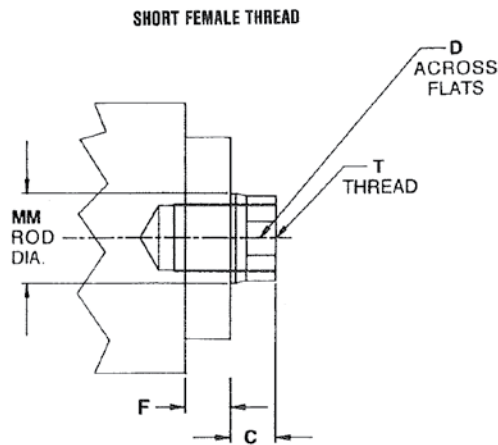
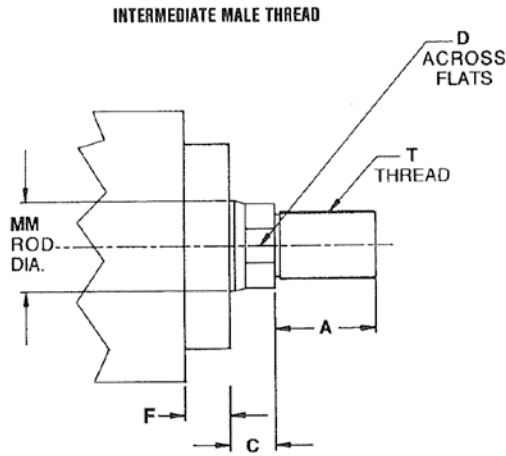
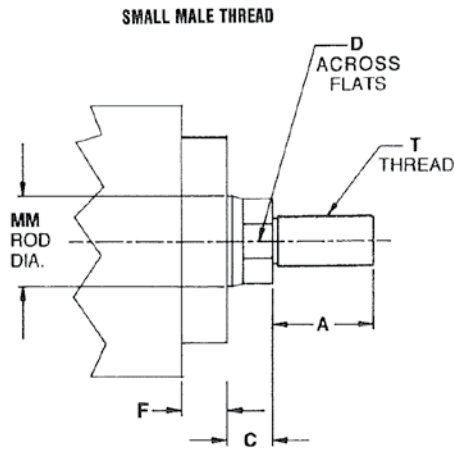

Dimensions are Affected by the Rod Diameter

MP1

BORE	CYLINDER		A	D	T (THREAD)		
	ROD DIA. CODE	MM ROD DIA.			SM SMALL MALE	IM INTER-MEDIATE MALE	SF SHORT FEMALE
2.00	F	1.00	1.12	.88	.75-16	.88-14	.75-16
	G	1.38	1.62	1.12	1.00-14	1.25-12	1.00-14
3.00	G	1.38	1.62	1.12	1.00-14	1.25-12	1.00-14
	H	1.75	2.00	1.50	1.25-12	1.50-12	1.25-12
	J	2.00	2.25	1.69	1.50-12	1.75-12	1.50-12
4.00	H	1.75	2.00	1.50	1.25-12	1.50-12	1.25-12
	J	2.00	2.25	1.69	1.50-12	1.75-12	1.50-12
	K	2.50	3.00	2.06	1.88-12	2.25-12	1.88-12
5.00	J	2.00	2.25	1.69	1.50-12	1.75-12	1.50-12
	K	2.50	3.00	2.06	1.88-12	2.25-12	1.88-12
	L	3.00	3.50	2.62	2.25-12	2.75-12	2.25-12
	M	3.50	3.50	3.00	2.50-12	3.25-12	2.50-12
6.00	K	2.50	3.00	2.06	1.88-12	2.25-12	1.88-12
	L	3.00	3.50	2.62	2.25-12	2.75-12	2.25-12
	M	3.50	3.50	3.00	2.50-12	3.25-12	2.50-12
	N	4.00	4.00	3.38	3.00-12	3.75-12	3.00-12
7.00	K	2.50	3.00	2.06	1.88-12	2.25-12	1.88-12
	L	3.00	3.50	2.62	2.25-12	2.75-12	2.25-12
	M	3.50	3.50	3.30	2.50-12	3.25-12	2.50-12
	N	4.00	4.00	3.38	3.00-12	3.75-12	3.00-12
	P	4.50	4.50	3.88	3.25-12	4.25-12	3.25-12
	R	5.00	5.00	4.25	3.50-12	4.75-12	3.50-12
8.00	L	3.00	3.50	2.62	2.25-12	2.75-12	2.25-12
	M	3.50	3.50	3.00	2.50-12	3.25-12	2.50-12
	N	4.00	4.00	3.38	3.00-12	3.75-12	3.00-12
	P	4.50	4.50	3.88	3.25-12	4.25-12	3.25-12
	R	5.00	5.00	4.25	3.50-12	4.75-12	3.50-12
	S	5.50	5.50	4.62	4.00-12	5.25-12	4.00-12
9.00	M	3.50	3.50	3.00	2.50-12	3.25-12	2.50-12
	N	4.00	4.00	3.38	3.00-12	3.75-12	3.00-12
	P	4.50	4.50	3.88	3.25-12	4.25-12	3.25-12
	R	5.00	5.00	4.25	3.50-12	4.75-12	3.50-12
	S	5.50	5.50	4.62	4.00-12	5.25-12	4.00-12
	Y	6.00	6.00	5.00	4.50-12	5.75-12	4.50-12
10.00	M	3.50	3.50	3.00	2.50-12	3.25-12	2.50-12
	N	4.00	4.00	3.38	3.00-12	3.75-12	3.00-12
	P	4.50	4.50	3.88	3.25-12	4.25-12	3.25-12
	R	5.00	5.00	4.25	3.50-12	4.75-12	3.50-12
	S	5.50	5.50	4.62	4.00-12	5.25-12	4.00-12
	T	7.00	7.00	—	5.50-12	—	—
12.00	N	4.00	4.00	3.38	3.00-12	3.75-12	3.00-12
	P	4.50	4.50	3.88	3.25-12	4.25-12	3.25-12
	R	5.00	5.00	4.25	3.50-12	4.75-12	3.50-12
	S	5.50	5.50	4.62	4.00-12	5.25-12	4.00-12
	T	7.00	7.00	—	5.50-12	—	—
14.00	S	5.50	5.50	4.62	4.00-12	5.25-12	4.00-12
	T	7.00	7.00	—	5.50-12	—	—
	U	8.00	8.00	—	6.50-12	—	—
16.00	S	5.50	5.50	4.62	4.00-12	5.25-12	4.00-12
	T	7.00	7.00	—	5.50-12	—	—
	U	8.00	8.00	—	6.50-12	—	—

SERIES MT 2.00"-16.00" Bores MP3 Fixed Single Ear Clevis Mount

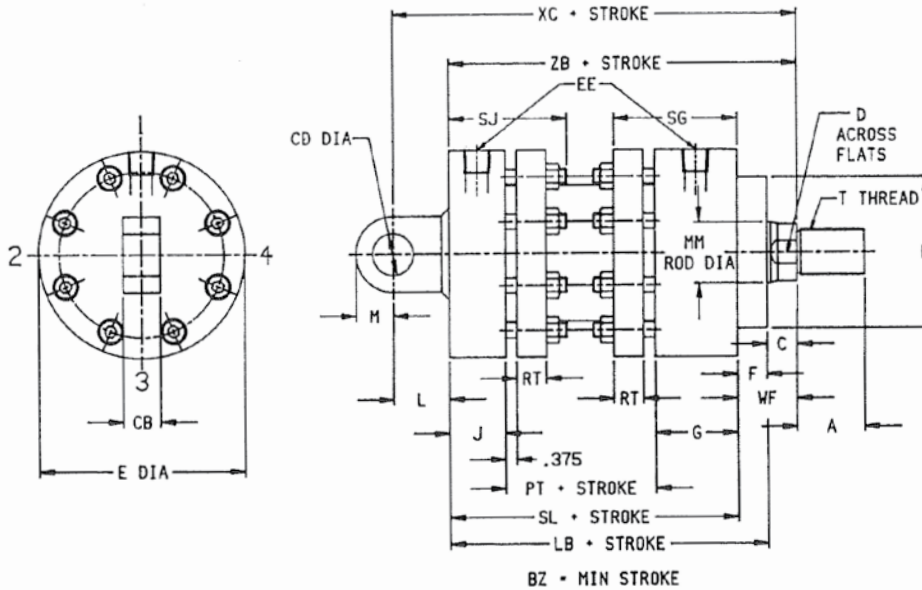

These Dimensions are Constant Regardless of Rod Diameter

BORE	B	BZ	C	CB ±.005	CD +0.003 +0.005	E	EE		F	G	J	L	LB	M	PT	RT
							SAE STRAIGHT THREAD	NPTF*								
2.00	3.25	1.38	0.81	1.00	0.750	4.12	#8 (.750-16)	0.50	1.00	2.25	1.38	1.31	6.00	0.75	1.38	0.50
3.00	4.50	1.75	0.88	1.25	1.250	5.38	#12 (1.062-12)	0.75	1.12	2.62	1.75	1.62	7.25	1.12	1.75	0.75
4.00	5.00	2.38	1.00	1.25	1.375	6.88	#12 (1.062-12)	0.75	1.00	2.75	1.88	1.88	7.62	1.25	2.00	1.00
5.00	6.38	2.88	1.00	1.25	1.500	8.25	#12 (1.062-12)	0.75	1.00	3.00	2.12	2.50	8.62	1.38	2.50	1.25
6.00	7.38	3.25	1.00	1.50	1.750	9.62	#16 (1.312-12)	1.00	1.25	3.25	2.25	3.12	9.62	1.62	2.88	1.62
7.00	8.25	3.38	1.00	3.00	2.000	10.75	#16 (1.312-12)	1.00	1.25	3.25	2.25	3.12	9.75	1.62	3.00	1.75
8.00	9.75	3.25	1.12	3.00	2.000	12.38	#20 (1.625-12)	1.25	1.43	3.62	2.50	3.62	11.06	1.88	3.50	1.88
9.00	9.75	3.25	1.12	3.00	2.000	13.38	#20 (1.625-12)	1.25	1.43	3.62	2.50	3.62	11.31	1.88	3.75	2.00
10.00	10.75	3.25	1.00	3.50	2.500	15.50	#24 (1.875-12)	1.50	1.43	4.25	3.12	4.06	13.56	2.38	4.75	2.38
12.00	10.75	3.25	1.12	4.50	3.000	18.75	#24 (1.875-12)	1.50	1.43	4.50	3.62	4.43	15.19	2.88	5.62	2.75
14.00	12.00	4.00	1.00	5.00	3.500	21.50	#32 (2.500-12)	2.00	2.00	5.00	4.25	5.19	17.00	3.38	5.75	3.25
16.00	12.00	3.00	2.25	6.00	4.250	23.62	#32 (2.500-12)	2.00	2.00	6.00	5.00	5.00	19.00	4.00	6.00	3.75

*NPTF ports will be furnished unless SAE straight thread ports are specified.
Optional SAE 4-Bolt Flange Ports may be specified—Flange furnished by customer.

BORE	SG	SJ	SL	WF	XC	ZB
2.00	3.47	2.59	5.00	1.81	8.12	6.81
3.00	4.22	3.34	6.12	2.00	9.75	8.12
4.00	4.78	3.91	6.62	2.00	10.50	8.62
5.00	5.41	4.53	7.62	2.00	12.12	9.62
6.00	6.19	5.19	8.38	2.25	13.75	10.62
7.00	6.69	5.69	8.50	2.25	13.88	10.75
8.00	6.81	5.69	9.62	2.56	15.81	12.19
9.00	6.81	5.69	9.88	2.56	16.06	12.43
10.00	7.91	6.78	12.12	2.43	18.62	14.56
12.00	8.78	7.91	13.75	2.56	20.75	16.31
14.00	9.66	8.91	15.00	3.00	23.19	18.00
16.00	10.03	9.03	17.00	4.25	26.25	21.25

NOTE: Dimensions are nominal except where specifically tolerated. Tolerances on "Plus Stroke" dimensions will vary slightly from dimensions shown due to manufacturing tolerances and tube compression.

NOTE: Pivot Pin not included.

STANDARD ROD END STYLES

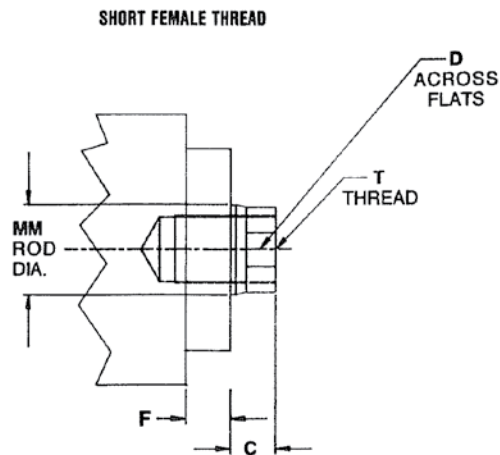
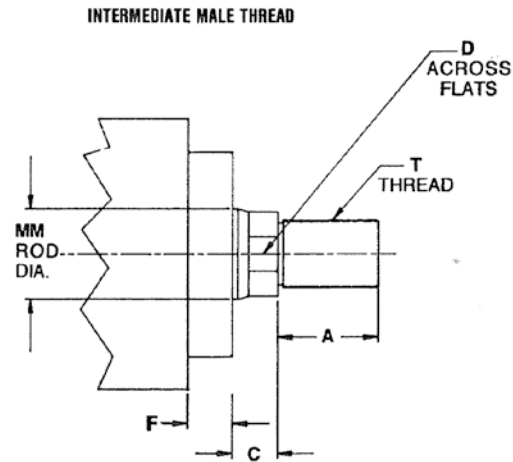
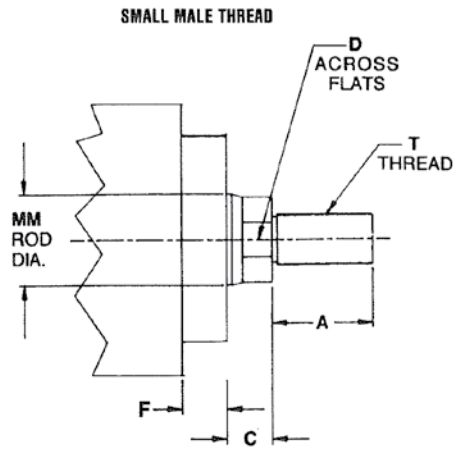

Dimensions are Affected by the Rod Diameter **MP3**

BORE	CYLINDER ROD DIA. CODE	MM ROD DIA.	A	D	T (THREAD)		
					SM SMALL MALE	IM INTER- MEDIATE MALE	SF SHORT FEMALE
2.00	F	1.00	1.12	.88	.75-16	.88-14	.75-16
	G	1.38	1.62	1.12	1.00-14	1.25-12	1.00-14
3.00	G	1.38	1.62	1.12	1.00-14	1.25-12	1.00-14
	H	1.75	2.00	1.50	1.25-12	1.50-12	1.25-12
4.00	J	2.00	2.25	1.69	1.50-12	1.75-12	1.50-12
	K	2.50	3.00	2.06	1.88-12	2.25-12	1.88-12
5.00	J	2.00	2.25	1.69	1.50-12	1.75-12	1.50-12
	K	2.50	3.00	2.06	1.88-12	2.25-12	1.88-12
	L	3.00	3.50	2.62	2.25-12	2.75-12	2.25-12
6.00	M	3.50	3.50	3.00	2.50-12	3.25-12	2.50-12
	K	2.50	3.00	2.06	1.88-12	2.25-12	1.88-12
	L	3.00	3.50	2.62	2.25-12	2.75-12	2.25-12
7.00	M	3.50	3.50	3.00	2.50-12	3.25-12	2.50-12
	N	4.00	4.00	3.38	3.00-12	3.75-12	3.00-12
	P	4.50	4.50	3.88	3.25-12	4.25-12	3.25-12
	R	5.00	5.00	4.25	3.50-12	4.75-12	3.50-12
8.00	L	3.00	3.50	2.62	2.25-12	2.75-12	2.25-12
	M	3.50	3.50	3.00	2.50-12	3.25-12	2.50-12
	N	4.00	4.00	3.38	3.00-12	3.75-12	3.00-12
	P	4.50	4.50	3.88	3.25-12	4.25-12	3.25-12
	R	5.00	5.00	4.25	3.50-12	4.75-12	3.50-12
	S	5.50	5.50	4.62	4.00-12	5.25-12	4.00-12
9.00	M	3.50	3.50	3.00	2.50-12	3.25-12	2.50-12
	N	4.00	4.00	3.38	3.00-12	3.75-12	3.00-12
	P	4.50	4.50	3.88	3.25-12	4.25-12	3.25-12
	R	5.00	5.00	4.25	3.50-12	4.75-12	3.50-12
	S	5.50	5.50	4.62	4.00-12	5.25-12	4.00-12
	Y	6.00	6.00	5.00	4.50-12	5.75-12	4.50-12
10.00	M	3.50	3.50	3.00	2.50-12	3.25-12	2.50-12
	N	4.00	4.00	3.38	3.00-12	3.75-12	3.00-12
	P	4.50	4.50	3.88	3.25-12	4.25-12	3.25-12
	R	5.00	5.00	4.25	3.50-12	4.75-12	3.50-12
	S	5.50	5.50	4.62	4.00-12	5.25-12	4.00-12
	T	7.00	7.00	—	5.50-12	—	—
12.00	N	4.00	4.00	3.38	3.00-12	3.75-12	3.00-12
	P	4.50	4.50	3.88	3.25-12	4.25-12	3.25-12
	R	5.00	5.00	4.25	3.50-12	4.75-12	3.50-12
	S	5.50	5.50	4.62	4.00-12	5.25-12	4.00-12
	T	7.00	7.00	—	5.50-12	—	—
14.00	S	5.50	5.50	4.62	4.00-12	5.25-12	4.00-12
	T	7.00	7.00	—	5.50-12	—	—
	U	8.00	8.00	—	6.50-12	—	—
16.00	S	5.50	5.50	4.62	4.00-12	5.25-12	4.00-12
	T	7.00	7.00	—	5.50-12	—	—

SERIES MT 2.00"-9.00" Bores MPU3 Spherical Bearing Mount

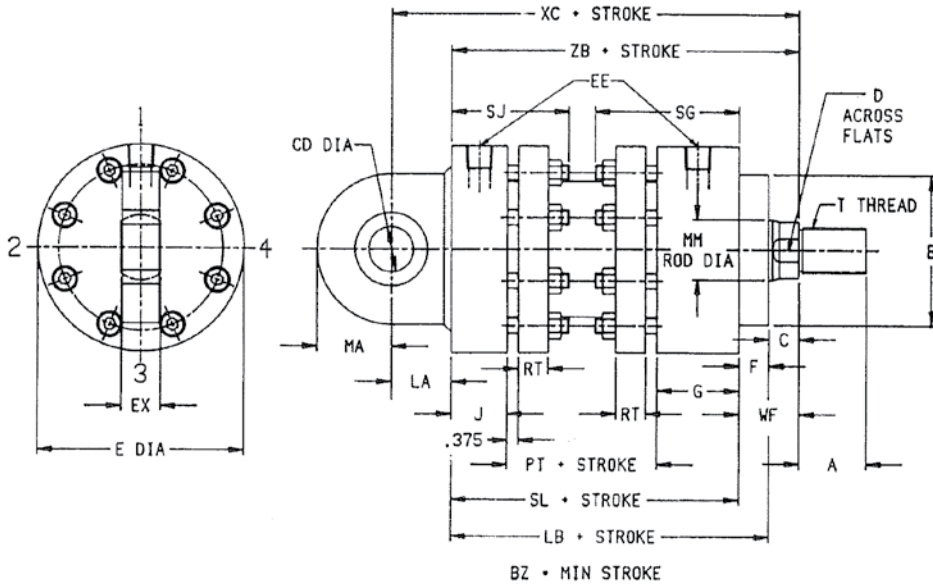

These Dimensions are Constant Regardless of Rod Diameter

BORE	B	BZ	C	CD +.000 -.001	E	EE		EX	F	G	J	LA	LB	MA	PT	RT
						SAE STRAIGHT THREAD	NPTF*									
2.00	3.25	1.38	0.81	0.750	4.12	#8 (.750-16)	0.50	0.656	1.00	2.25	1.38	1.25	6.00	1.25	1.38	0.50
3.00	4.50	1.75	0.88	1.250	5.38	#12 (1.062-12)	0.75	1.093	1.12	2.62	1.75	1.75	7.25	2.00	1.75	0.75
4.00	5.00	2.38	1.00	1.500	6.88	#12 (1.062-12)	0.75	1.312	1.00	2.75	1.88	2.00	7.62	2.50	2.00	1.00
5.00	6.38	2.88	1.00	2.000	8.25	#12 (1.062-12)	0.75	1.750	1.00	3.00	2.12	2.50	8.62	3.25	2.50	1.25
6.00	7.38	3.25	1.00	2.250	9.62	#16 (1.312-12)	1.00	1.969	1.25	3.25	2.25	2.75	9.62	3.62	2.88	1.62
7.00	8.25	3.38	1.00	2.750	10.75	#16 (1.312-12)	1.00	2.406	1.25	3.25	2.25	3.00	9.75	4.38	3.00	1.75
8.00	9.75	3.25	1.12	3.000	12.38	#20 (1.625-12)	1.25	2.625	1.43	3.62	2.50	3.25	11.06	4.75	3.50	1.88
9.00	9.75	3.25	1.12	3.000	13.38	#20 (1.625-12)	1.25	2.625	1.43	3.62	2.50	3.25	11.31	4.75	3.75	2.00

*NPTF ports will be furnished unless SAE straight thread ports are specified.
Optional SAE 4-Bolt Flange Ports may be specified—Flange furnished by customer.

BORE	SG	SJ	SL	WF	XC	ZB
2.00	3.47	2.59	5.00	1.81	8.06	6.81
3.00	4.22	3.34	6.12	2.00	9.88	8.12
4.00	4.78	3.91	6.62	2.00	10.62	8.62
5.00	5.41	4.53	7.62	2.00	12.12	9.62
6.00	6.19	5.19	8.38	2.25	13.38	10.62
7.00	6.69	5.69	8.50	2.25	13.75	10.75
8.00	6.81	5.69	9.62	2.56	15.43	12.19
9.00	6.81	5.69	9.88	2.56	15.69	12.43

NOTE: Dimensions are nominal except where specifically toleranced. Tolerances on "Plus Stroke" dimensions will vary slightly from dimensions shown due to manufacturing tolerances and tube compression.

NOTE: Spherical Bearing is rated for 2000 P.S.I. Dynamic Load.

STANDARD ROD END STYLES

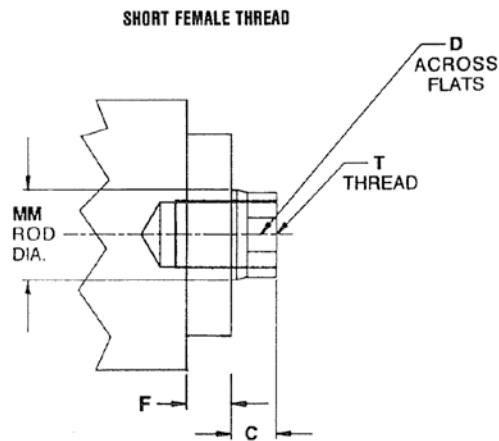
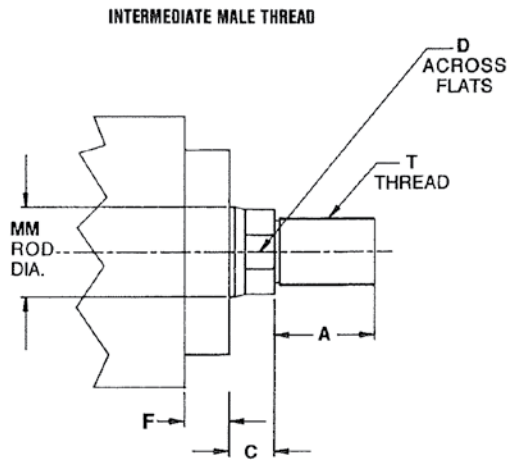
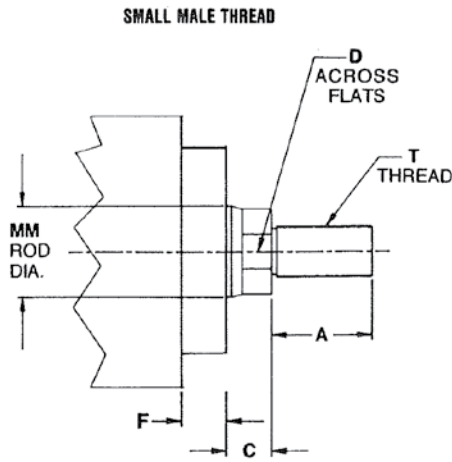

Dimensions are Affected by the Rod Diameter **MPU3**

BORE	ROD DIA. CODE	CYLINDER		A	D	T (THREAD)		
		MM ROD DIA.				SM SMALL MALE	IM INTER-MEDIATE MALE	SF SHORT FEMALE
2.00	F	1.00	1.12	.88	.75-16	.88-14	.75-16	
	G	1.38	1.62	1.12	1.00-14	1.25-12	1.00-14	
3.00	G	1.38	1.62	1.12	1.00-14	1.25-12	1.00-14	
	H	1.75	2.00	1.50	1.25-12	1.50-12	1.25-12	
	J	2.00	2.25	1.69	1.50-12	1.75-12	1.50-12	
4.00	H	1.75	2.00	1.50	1.25-12	1.50-12	1.25-12	
	J	2.00	2.25	1.69	1.50-12	1.75-12	1.50-12	
	K	2.50	3.00	2.06	1.88-12	2.25-12	1.88-12	
5.00	J	2.00	2.25	1.69	1.50-12	1.75-12	1.50-12	
	K	2.50	3.00	2.06	1.88-12	2.25-12	1.88-12	
	L	3.00	3.50	2.62	2.25-12	2.75-12	2.25-12	
	M	3.50	3.50	3.00	2.50-12	3.25-12	2.50-12	
6.00	K	2.50	3.00	2.06	1.88-12	2.25-12	1.88-12	
	L	3.00	3.50	2.62	2.25-12	2.75-12	2.25-12	
	M	3.50	3.50	3.00	2.50-12	3.25-12	2.50-12	
	N	4.00	4.00	3.38	3.00-12	3.75-12	3.00-12	
7.00	K	2.50	3.00	2.06	1.88-12	2.25-12	1.88-12	
	L	3.00	3.50	2.62	2.25-12	2.75-12	2.25-12	
	M	3.50	3.50	3.30	2.50-12	3.25-12	2.50-12	
	N	4.00	4.00	3.38	3.00-12	3.75-12	3.00-12	
	P	4.50	4.50	3.88	3.25-12	4.25-12	3.25-12	
8.00	R	5.00	5.00	4.25	3.50-12	4.75-12	3.50-12	
	S	5.50	5.50	4.62	4.00-12	5.25-12	4.00-12	
	L	3.00	3.50	2.62	2.25-12	2.75-12	2.25-12	
	M	3.50	3.50	3.00	2.50-12	3.25-12	2.50-12	
	N	4.00	4.00	3.38	3.00-12	3.75-12	3.00-12	
9.00	P	4.50	4.50	3.88	3.25-12	4.25-12	3.25-12	
	R	5.00	5.00	4.25	3.50-12	4.75-12	3.50-12	
	S	5.50	5.50	4.62	4.00-12	5.25-12	4.00-12	
	M	3.50	3.50	3.00	2.50-12	3.25-12	2.50-12	
	N	4.00	4.00	3.38	3.00-12	3.75-12	3.00-12	
	Y	6.00	6.00	5.00	4.50-12	5.75-12	4.50-12	

SERIES MT 2.00"-16.00" Bores

MT4 Intermediate Fixed Trunnion Mount

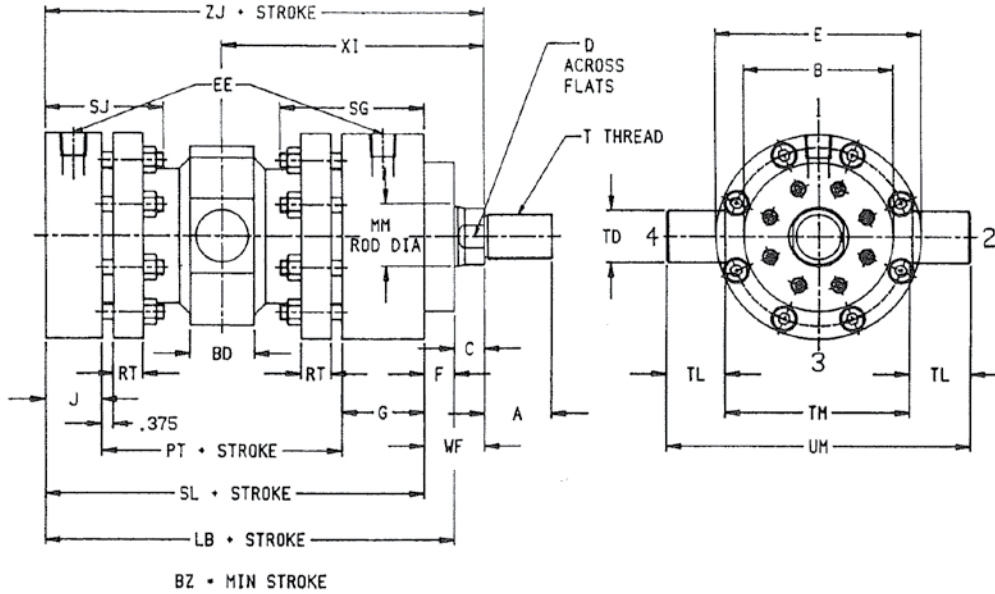

These Dimensions are Constant Regardless of Rod Diameter

BORE	B	BD	BZ	C	E	EE		F	G	J	LB	PT	RT	SG	SJ	SL
						SAE STRAIGHT THREAD	NPTF*									
2.00	3.25	1.50	1.38	0.81	4.12	#8 (.750-16)	0.50	1.00	2.25	1.38	6.00	1.38	0.50	3.47	2.59	5.00
3.00	4.50	1.62	1.75	0.88	5.38	#12 (1.062-12)	0.75	1.12	2.62	1.75	7.25	1.75	0.75	4.22	3.34	6.12
4.00	5.00	2.12	2.38	1.00	6.88	#12 (1.062-12)	0.75	1.00	2.75	1.88	7.62	2.00	1.00	4.78	3.91	6.62
5.00	6.38	2.38	2.88	1.00	8.25	#12 (1.062-12)	0.75	1.00	3.00	2.12	8.62	2.50	1.25	5.41	4.53	7.62
6.00	7.38	2.38	3.25	1.00	9.62	#16 (1.312-12)	1.00	1.25	3.25	2.25	9.62	2.88	1.62	6.19	5.19	8.38
7.00	8.25	2.38	3.38	1.00	10.75	#16 (1.312-12)	1.00	1.25	3.25	2.25	9.75	3.00	1.75	6.69	5.69	8.50
8.00	9.75	2.88	3.25	1.12	12.38	#20 (1.625-12)	1.25	1.43	3.62	2.50	11.06	3.50	1.88	6.81	5.69	9.62
9.00	9.75	2.88	3.25	1.12	13.38	#20 (1.625-12)	1.25	1.43	3.62	2.50	11.31	3.75	2.00	6.81	5.69	9.88
10.00	10.75	3.38	3.25	1.00	15.50	#24 (1.875-12)	1.50	1.43	4.25	3.12	13.56	4.75	2.38	7.91	6.78	12.12
12.00	10.75	4.88	3.25	1.12	18.75	#24 (1.875-12)	1.50	1.43	4.50	3.62	15.19	5.62	2.75	8.78	7.91	13.75
14.00	12.00	5.50	4.00	1.00	21.50	#32 (2.500-12)	2.00	2.00	5.00	4.25	17.00	5.75	3.25	9.66	8.91	15.00
16.00	12.00	5.50	3.00	2.25	23.62	#32 (2.500-12)	2.00	2.00	6.00	5.00	19.00	6.00	3.75	10.03	9.03	17.00

*NPTF ports will be furnished unless SAE straight thread ports are specified.
Optional SAE 4-Bolt Flange Ports may be specified—Flange furnished by customer.

BORE	TD +.000 -.002	TL	TM	UM	WF	XI MIN.	ZJ
2.00	1.250	1.25	3.75	6.25	1.81	6.50	6.81
3.00	1.375	1.38	5.12	7.88	2.00	7.00	8.12
4.00	1.750	1.75	6.62	10.12	2.00	8.50	8.62
5.00	2.000	2.00	7.56	11.56	2.00	9.50	9.62
6.00	2.250	2.25	9.12	13.62	2.25	10.25	10.62
7.00	2.250	2.25	10.12	14.62	2.25	11.00	10.75
8.00	2.500	2.50	11.43	16.43	2.56	11.75	12.19
9.00	2.500	2.50	12.43	17.43	2.56	11.75	12.43
10.00	3.000	3.00	16.50	22.50	2.43	13.00	14.56
12.00	3.500	3.50	19.00	26.00	2.56	15.25	16.31
14.00	4.500	4.50	21.50	30.50	3.00	16.75	18.00
16.00	5.000	5.00	23.50	33.50	4.25	18.75	21.25

NOTE: Trunnion location (XI) must be specified when ordering.

NOTE: Align and mount pillow blocks to avoid bending moments in trunnions.

NOTE: Dimensions are nominal except where specifically toleranced. Tolerances on "Plus Stroke" dimensions will vary slightly from dimensions shown due to manufacturing tolerances and tube compression.

STANDARD ROD END STYLES

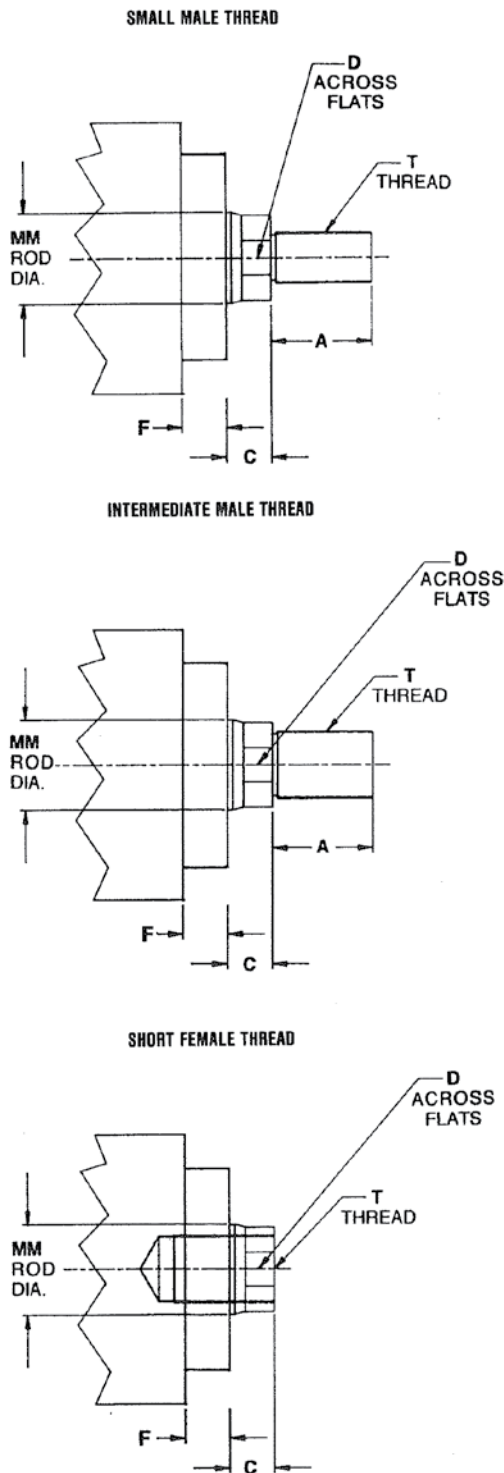

Dimensions are Affected by the Rod Diameter **MT4**

BORE	ROD DIA. CODE	CYLINDER		A	D	T (THREAD)		
		MM ROD DIA.				SM SMALL MALE	IM INTER-MEDIATE MALE	SF SHORT FEMALE
2.00	F	1.00		1.12	.88	.75-16	.88-14	.75-16
	G	1.38		1.62	1.12	1.00-14	1.25-12	1.00-14
3.00	G	1.38		1.62	1.12	1.00-14	1.25-12	1.00-14
	H	1.75		2.00	1.50	1.25-12	1.50-12	1.25-12
4.00	J	2.00		2.25	1.69	1.50-12	1.75-12	1.50-12
	K	2.50		3.00	2.06	1.88-12	2.25-12	1.88-12
5.00	J	2.00		2.25	1.69	1.50-12	1.75-12	1.50-12
	K	2.50		3.00	2.06	1.88-12	2.25-12	1.88-12
	L	3.00		3.50	2.62	2.25-12	2.75-12	2.25-12
6.00	M	3.50		4.00	3.00	2.50-12	3.25-12	2.50-12
	N	4.00		4.00	3.38	3.00-12	3.75-12	3.00-12
	K	2.50		3.00	2.06	1.88-12	2.25-12	1.88-12
	L	3.00		3.50	2.62	2.25-12	2.75-12	2.25-12
7.00	M	3.50		4.00	3.38	3.25-12	3.75-12	2.50-12
	N	4.00		4.00	3.38	3.00-12	3.75-12	3.00-12
	P	4.50		4.50	3.88	3.25-12	4.25-12	3.25-12
	R	5.00		5.00	4.25	3.50-12	4.75-12	3.50-12
8.00	L	3.00		3.50	2.62	2.25-12	2.75-12	2.25-12
	M	3.50		4.00	3.38	3.00-12	3.75-12	3.00-12
	N	4.00		4.00	3.38	3.00-12	3.75-12	3.00-12
	P	4.50		4.50	3.88	3.25-12	4.25-12	3.25-12
	R	5.00		5.00	4.25	3.50-12	4.75-12	3.50-12
	S	5.50		5.50	4.62	4.00-12	5.25-12	4.00-12
9.00	M	3.50		4.00	3.38	3.00-12	3.75-12	3.00-12
	N	4.00		4.00	3.38	3.00-12	3.75-12	3.00-12
	P	4.50		4.50	3.88	3.25-12	4.25-12	3.25-12
	R	5.00		5.00	4.25	3.50-12	4.75-12	3.50-12
	S	5.50		5.50	4.62	4.00-12	5.25-12	4.00-12
	Y	6.00		6.00	5.00	4.50-12	5.75-12	4.50-12
10.00	M	3.50		4.00	3.38	3.00-12	3.75-12	3.00-12
	N	4.00		4.00	3.38	3.00-12	3.75-12	3.00-12
	P	4.50		4.50	3.88	3.25-12	4.25-12	3.25-12
	R	5.00		5.00	4.25	3.50-12	4.75-12	3.50-12
	S	5.50		5.50	4.62	4.00-12	5.25-12	4.00-12
	T	7.00		7.00	—	5.50-12	—	—
12.00	N	4.00		4.00	3.38	3.00-12	3.75-12	3.00-12
	P	4.50		4.50	3.88	3.25-12	4.25-12	3.25-12
	R	5.00		5.00	4.25	3.50-12	4.75-12	3.50-12
	S	5.50		5.50	4.62	4.00-12	5.25-12	4.00-12
14.00	T	7.00		7.00	—	5.50-12	—	—
	U	8.00		8.00	—	6.50-12	—	—
	S	5.50		5.50	4.62	4.00-12	5.25-12	4.00-12
16.00	T	7.00		7.00	—	5.50-12	—	—
	U	8.00		8.00	—	6.50-12	—	—

SERIES MT 2.00"-16.00" Bores ME5 Head Flange Mount

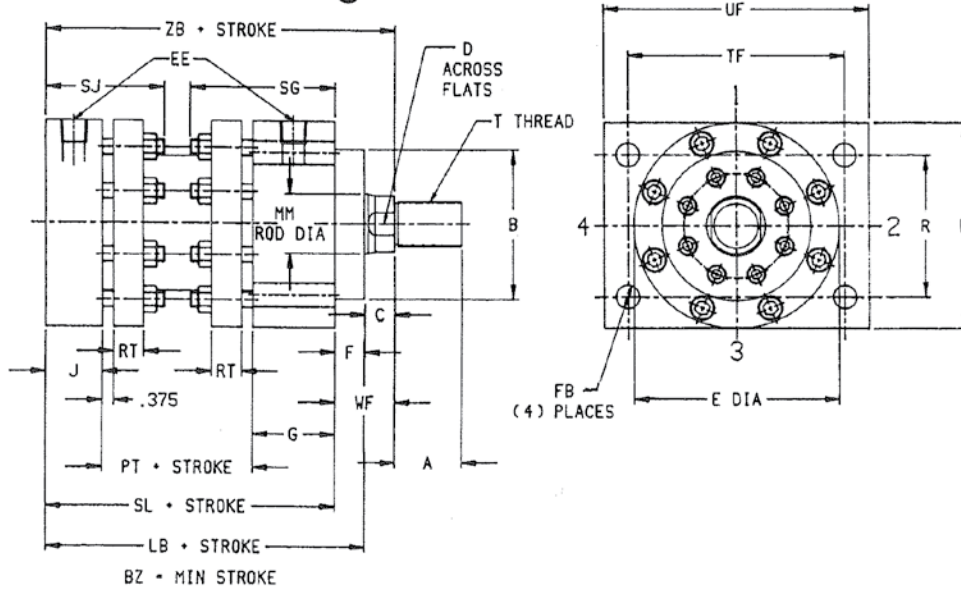

These Dimensions are Constant Regardless of Rod Diameter

BORE	B	BZ	C	E	EE		F	FB	G	J	LB	PT	R	RT	SG
					SAE STRAIGHT THREAD	NPTF*									
2.00	3.25	1.38	0.81	4.12	#8 (.750-16)	0.50	1.00	0.41	2.25	1.38	6.00	1.38	2.50	0.50	3.47
3.00	4.50	1.75	0.88	5.38	#12 (1.062-12)	0.75	1.12	0.66	2.62	1.75	7.25	1.75	3.38	0.75	4.22
4.00	5.00	2.38	1.00	6.88	#12 (1.062-12)	0.75	1.00	0.78	2.75	1.88	7.62	2.00	4.75	1.00	4.78
5.00	6.38	2.88	1.00	8.25	#12 (1.062-12)	0.75	1.00	1.03	3.00	2.12	8.62	2.50	5.62	1.25	5.41
6.00	7.38	3.25	1.00	9.62	#16 (1.312-12)	1.00	1.25	1.28	3.25	2.25	9.62	2.88	5.88	1.62	6.19
7.00	8.25	3.38	1.00	10.75	#16 (1.312-12)	1.00	1.25	1.28	3.25	2.25	9.75	3.00	6.88	1.75	6.69
8.00	9.75	3.25	1.12	12.38	#20 (1.625-12)	1.25	1.43	1.53	3.62	2.50	11.06	3.50	8.50	1.88	6.81
9.00	9.75	3.25	1.12	13.38	#20 (1.625-12)	1.25	1.43	1.53	3.62	2.50	11.31	3.75	9.50	2.00	6.81
10.00	10.75	3.25	1.00	15.50	#24 (1.875-12)	1.50	1.43	1.78	4.25	3.12	13.56	4.75	11.50	2.38	7.91
12.00	10.75	3.25	1.12	18.75	#24 (1.875-12)	1.50	1.43	2.06	4.50	3.62	15.19	5.62	14.50	2.75	8.78
14.00	12.00	4.00	1.00	21.50	#32 (2.500-12)	2.00	2.00	2.06	5.00	4.25	17.00	5.75	16.00	3.25	9.66
16.00	12.00	3.00	2.25	23.62	#32 (2.500-12)	2.00	2.00	2.56	6.00	5.00	19.00	6.00	17.50	3.75	10.03

*NPTF ports will be furnished unless SAE straight thread ports are specified.
Optional SAE 4-Bolt Flange Ports may be specified—Flange furnished by customer.

BORE	SJ	SL	TF	UF	WF	ZB
2.00	2.59	5.00	4.25	5.12	1.81	6.81
3.00	3.34	6.12	5.75	7.12	2.00	8.12
4.00	3.91	6.62	7.25	8.88	2.00	8.62
5.00	4.53	7.62	8.50	10.25	2.00	9.62
6.00	5.19	8.38	10.25	13.25	2.25	10.62
7.00	5.69	8.50	11.25	14.25	2.25	10.75
8.00	5.69	9.62	12.50	15.25	2.56	12.19
9.00	5.69	9.88	13.50	16.25	2.56	12.43
10.00	6.78	12.12	15.50	19.00	2.43	14.56
12.00	7.91	13.75	17.50	21.00	2.56	16.31
14.00	8.91	15.00	20.00	24.00	3.00	18.00
16.00	9.03	17.00	22.00	25.50	4.25	21.25

NOTE: Dimensions are nominal except where specifically tolerated. Tolerances on "Plus Stroke" dimensions will vary slightly from dimensions shown due to manufacturing tolerances and tube compression.

STANDARD ROD END STYLES

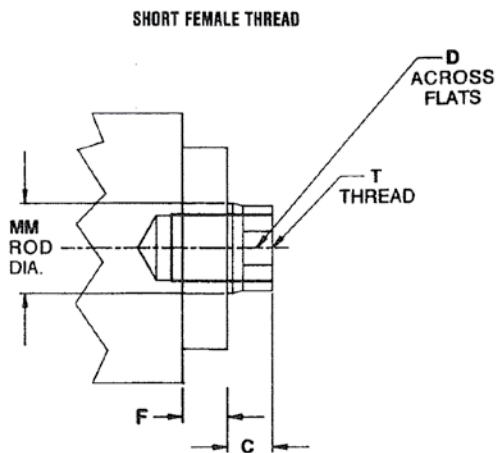
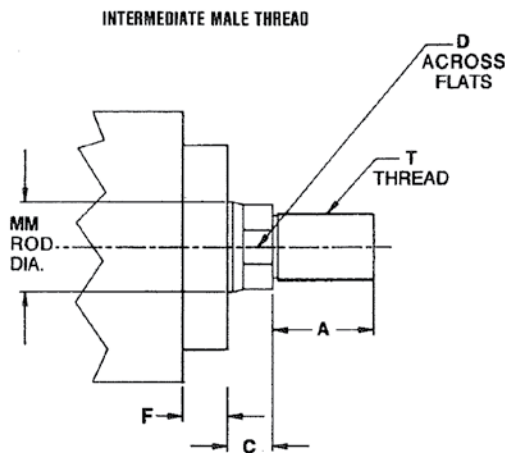
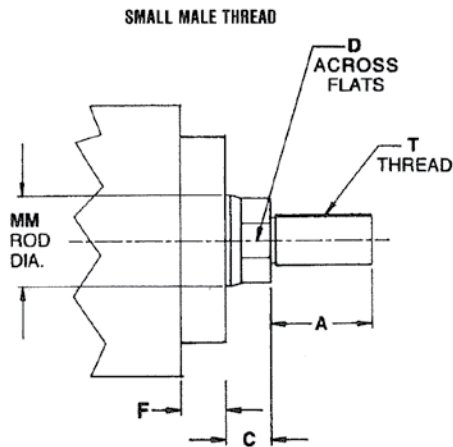

Dimensions are Affected by the Rod Diameter **ME5**

BORE	CYLINDER		A	D	T (THREAD)			
	ROD DIA. CODE	MM ROD DIA.			SM SMALL MALE	IM INTER-MEDIATE MALE	SF SHORT FEMALE	
2.00	F	1.00	1.12	.88	.75-16	.88-14	.75-16	
	G	1.38	1.62	1.12	1.00-14	1.25-12	1.00-14	
3.00	G	1.38	1.62	1.12	1.00-14	1.25-12	1.00-14	
	H	1.75	2.00	1.50	1.25-12	1.50-12	1.25-12	
	J	2.00	2.25	1.69	1.50-12	1.75-12	1.50-12	
4.00	H	1.75	2.00	1.50	1.25-12	1.50-12	1.25-12	
	J	2.00	2.25	1.69	1.50-12	1.75-12	1.50-12	
	K	2.50	3.00	2.06	1.88-12	2.25-12	1.88-12	
5.00	J	2.00	2.25	1.69	1.50-12	1.75-12	1.50-12	
	K	2.50	3.00	2.06	1.88-12	2.25-12	1.88-12	
	L	3.00	3.50	2.62	2.25-12	2.75-12	2.25-12	
	M	3.50	3.50	3.00	2.50-12	3.25-12	2.50-12	
6.00	K	2.50	3.00	2.06	1.88-12	2.25-12	1.88-12	
	L	3.00	3.50	2.62	2.25-12	2.75-12	2.25-12	
	M	3.50	3.50	3.00	2.50-12	3.25-12	2.50-12	
	N	4.00	4.00	3.38	3.00-12	3.75-12	3.00-12	
7.00	K	2.50	3.00	2.06	1.88-12	2.25-12	1.88-12	
	L	3.00	3.50	2.62	2.25-12	2.75-12	2.25-12	
	M	3.50	3.50	3.30	2.50-12	3.25-12	2.50-12	
	N	4.00	4.00	3.38	3.00-12	3.75-12	3.00-12	
	P	4.50	4.50	3.88	3.25-12	4.25-12	3.25-12	
	R	5.00	5.00	4.25	3.50-12	4.75-12	3.50-12	
8.00	L	3.00	3.50	2.62	2.25-12	2.75-12	2.25-12	
	M	3.50	3.50	3.00	2.50-12	3.25-12	2.50-12	
	N	4.00	4.00	3.38	3.00-12	3.75-12	3.00-12	
	P	4.50	4.50	3.88	3.25-12	4.25-12	3.25-12	
	R	5.00	5.00	4.25	3.50-12	4.75-12	3.50-12	
	S	5.50	5.50	4.62	4.00-12	5.25-12	4.00-12	
	9.00	M	3.50	3.50	3.00	2.50-12	3.25-12	2.50-12
		N	4.00	4.00	3.38	3.00-12	3.75-12	3.00-12
P		4.50	4.50	3.88	3.25-12	4.25-12	3.25-12	
R		5.00	5.00	4.25	3.50-12	4.75-12	3.50-12	
S		5.50	5.50	4.62	4.00-12	5.25-12	4.00-12	
Y		6.00	6.00	5.00	4.50-12	5.75-12	4.50-12	
10.00	M	3.50	3.50	3.00	2.50-12	3.25-12	2.50-12	
	N	4.00	4.00	3.38	3.00-12	3.75-12	3.00-12	
	P	4.50	4.50	3.88	3.25-12	4.25-12	3.25-12	
	R	5.00	5.00	4.25	3.50-12	4.75-12	3.50-12	
	S	5.50	5.50	4.62	4.00-12	5.25-12	4.00-12	
	T	7.00	7.00	—	5.50-12	—	—	
12.00	N	4.00	4.00	3.38	3.00-12	3.75-12	3.00-12	
	P	4.50	4.50	3.88	3.25-12	4.25-12	3.25-12	
	R	5.00	5.00	4.25	3.50-12	4.75-12	3.50-12	
	S	5.50	5.50	4.62	4.00-12	5.25-12	4.00-12	
	T	7.00	7.00	—	5.50-12	—	—	
14.00	S	5.50	5.50	4.62	4.00-12	5.25-12	4.00-12	
	T	7.00	7.00	—	5.50-12	—	—	
	U	8.00	8.00	—	6.50-12	—	—	
16.00	S	5.50	5.50	4.62	4.00-12	5.25-12	4.00-12	
	T	7.00	7.00	—	5.50-12	—	—	
	U	8.00	8.00	—	6.50-12	—	—	

SERIES MT 2.00"-16.00" Bores ME6 Cap Flange Mount

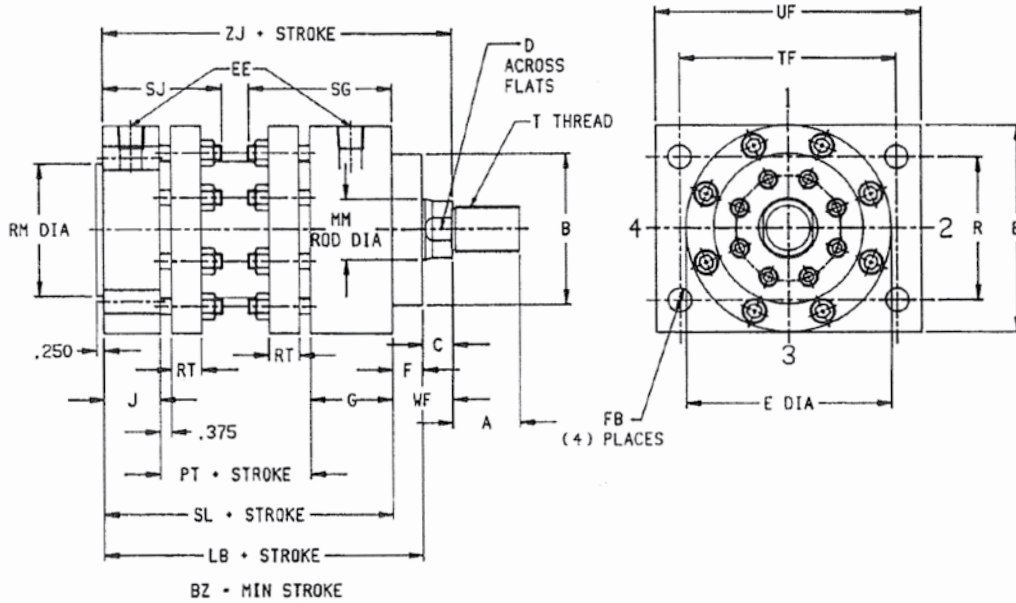

These Dimensions are Constant Regardless of Rod Diameter

BORE	B	BZ	C	E	EE		F	FB	G	J	LB	PT	R	RM +.000 -.002	RT	SG
					SAE STRAIGHT THREAD	NPTF*										
2.00	3.25	1.38	0.81	4.12	#8 (.750-16)	0.50	1.00	0.41	2.25	1.38	6.00	1.38	2.50	2.000	0.50	3.47
3.00	4.50	1.75	0.88	5.38	#12 (1.062-12)	0.75	1.12	0.66	2.62	1.75	7.25	1.75	3.38	3.625	0.75	4.22
4.00	5.00	2.38	1.00	6.88	#12 (1.062-12)	0.75	1.00	0.78	2.75	1.88	7.62	2.00	4.75	4.375	1.00	4.78
5.00	6.38	2.88	1.00	8.25	#12 (1.062-12)	0.75	1.00	1.03	3.00	2.12	8.62	2.50	5.62	5.000	1.25	5.41
6.00	7.38	3.25	1.00	9.62	#16 (1.312-12)	1.00	1.25	1.28	3.25	2.25	9.62	2.88	5.88	6.000	1.62	6.19
7.00	8.25	3.38	1.00	10.75	#16 (1.312-12)	1.00	1.25	1.28	3.25	2.25	9.75	3.00	6.88	6.000	1.75	6.69
8.00	9.75	3.25	1.12	12.38	#20 (1.625-12)	1.25	1.43	1.53	3.62	2.50	11.06	3.50	8.50	8.000	1.88	6.81
9.00	9.75	3.25	1.12	13.38	#20 (1.625-12)	1.25	1.43	1.53	3.62	2.50	11.31	3.75	9.50	9.000	2.00	6.81
10.00	10.75	3.25	1.00	15.50	#24 (1.875-12)	1.50	1.43	1.78	4.25	3.12	13.56	4.75	11.50	10.000	2.38	7.91
12.00	10.75	3.25	1.12	18.75	#24 (1.875-12)	1.50	1.43	2.06	4.50	3.62	15.19	5.62	14.50	12.000	2.75	8.78
14.00	12.00	4.00	1.00	21.50	#32 (2.500-12)	2.00	2.00	2.06	5.00	4.25	17.00	5.75	16.00	13.000	3.25	9.66
16.00	12.00	3.00	2.25	23.62	#32 (2.500-12)	2.00	2.00	2.56	6.00	5.00	19.00	6.00	17.50	14.250	3.75	10.03

*NPTF ports will be furnished unless SAE straight thread ports are specified.
Optional SAE 4-Bolt Flange Ports may be specified—Flange furnished by customer.

BORE	SJ	SL	TF	UF	WF	ZJ
2.00	2.59	5.00	4.25	5.12	1.81	6.81
3.00	3.34	6.12	5.75	7.12	2.00	8.12
4.00	3.91	6.62	7.25	8.88	2.00	8.62
5.00	4.53	7.62	8.50	10.25	2.00	9.62
6.00	5.19	8.38	10.25	13.25	2.25	10.62
7.00	5.69	8.50	11.25	14.25	2.25	10.75
8.00	5.69	9.62	12.50	15.25	2.56	12.19
9.00	5.69	9.88	13.50	16.25	2.56	12.43
10.00	6.78	12.12	15.50	19.00	2.43	14.56
12.00	7.91	13.75	17.50	21.00	2.56	16.31
14.00	8.91	15.00	20.00	24.00	3.00	18.00
16.00	9.03	17.00	22.00	25.50	4.25	21.25

NOTE: Dimensions are nominal except where specifically toleranced. Tolerances on "Plus Stroke" dimensions will vary slightly from dimensions shown due to manufacturing tolerances and tube compression.

STANDARD ROD END STYLES

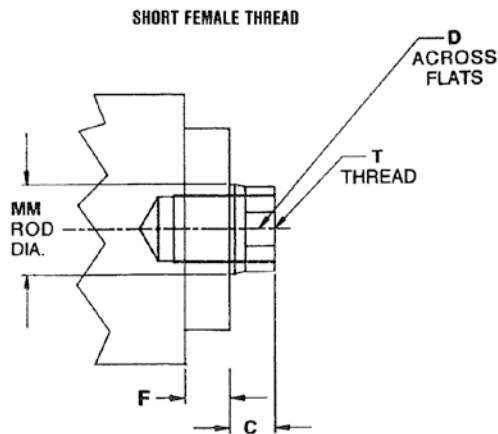
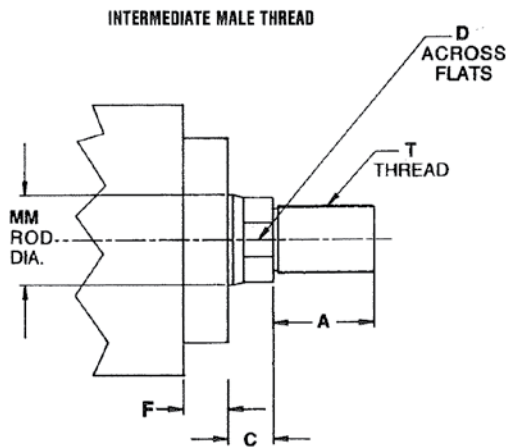
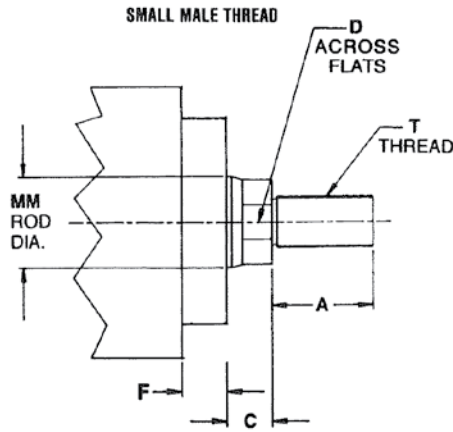

Dimensions are Affected by the Rod Diameter **ME6**

BORE	CYLINDER		A	D	T (THREAD)		
	ROD DIA. CODE	MM ROD DIA.			SM SMALL MALE	IM INTER-MEDIATE MALE	SF SHORT FEMALE
2.00	F	1.00	1.12	.88	.75-16	.88-14	.75-16
	G	1.38	1.62	1.12	1.00-14	1.25-12	1.00-14
3.00	G	1.38	1.62	1.12	1.00-14	1.25-12	1.00-14
	H	1.75	2.00	1.50	1.25-12	1.50-12	1.25-12
3.00	J	2.00	2.25	1.69	1.50-12	1.75-12	1.50-12
	K	2.50	3.00	2.06	1.88-12	2.25-12	1.88-12
4.00	H	1.75	2.00	1.50	1.25-12	1.50-12	1.25-12
	J	2.00	2.25	1.69	1.50-12	1.75-12	1.50-12
4.00	K	2.50	3.00	2.06	1.88-12	2.25-12	1.88-12
	L	3.00	3.50	2.62	2.25-12	2.75-12	2.25-12
5.00	K	2.50	3.00	2.06	1.88-12	2.25-12	1.88-12
	L	3.00	3.50	2.62	2.25-12	2.75-12	2.25-12
5.00	M	3.50	3.50	3.00	2.50-12	3.25-12	2.50-12
	N	4.00	4.00	3.38	3.00-12	3.75-12	3.00-12
6.00	K	2.50	3.00	2.06	1.88-12	2.25-12	1.88-12
	L	3.00	3.50	2.62	2.25-12	2.75-12	2.25-12
6.00	M	3.50	3.50	3.00	2.50-12	3.25-12	2.50-12
	N	4.00	4.00	3.38	3.00-12	3.75-12	3.00-12
7.00	K	2.50	3.00	2.06	1.88-12	2.25-12	1.88-12
	L	3.00	3.50	2.62	2.25-12	2.75-12	2.25-12
7.00	M	3.50	3.50	3.30	2.50-12	3.25-12	2.50-12
	N	4.00	4.00	3.38	3.00-12	3.75-12	3.00-12
7.00	P	4.50	4.50	3.88	3.25-12	4.25-12	3.25-12
	R	5.00	5.00	4.25	3.50-12	4.75-12	3.50-12
8.00	L	3.00	3.50	2.62	2.25-12	2.75-12	2.25-12
	M	3.50	3.50	3.00	2.50-12	3.25-12	2.50-12
8.00	N	4.00	4.00	3.38	3.00-12	3.75-12	3.00-12
	P	4.50	4.50	3.88	3.25-12	4.25-12	3.25-12
8.00	R	5.00	5.00	4.25	3.50-12	4.75-12	3.50-12
	S	5.50	5.50	4.62	4.00-12	5.25-12	4.00-12
9.00	M	3.50	3.50	3.00	2.50-12	3.25-12	2.50-12
	N	4.00	4.00	3.38	3.00-12	3.75-12	3.00-12
9.00	P	4.50	4.50	3.88	3.25-12	4.25-12	3.25-12
	R	5.00	5.00	4.25	3.50-12	4.75-12	3.50-12
9.00	S	5.50	5.50	4.62	4.00-12	5.25-12	4.00-12
	Y	6.00	6.00	5.00	4.50-12	5.75-12	4.50-12
10.00	M	3.50	3.50	3.00	2.50-12	3.25-12	2.50-12
	N	4.00	4.00	3.38	3.00-12	3.75-12	3.00-12
10.00	P	4.50	4.50	3.88	3.25-12	4.25-12	3.25-12
	R	5.00	5.00	4.25	3.50-12	4.75-12	3.50-12
10.00	S	5.50	5.50	4.62	4.00-12	5.25-12	4.00-12
	T	7.00	7.00	—	5.50-12	—	—
12.00	N	4.00	4.00	3.38	3.00-12	3.75-12	3.00-12
	P	4.50	4.50	3.88	3.25-12	4.25-12	3.25-12
12.00	R	5.00	5.00	4.25	3.50-12	4.75-12	3.50-12
	S	5.50	5.50	4.62	4.00-12	5.25-12	4.00-12
12.00	T	7.00	7.00	—	5.50-12	—	—
	U	8.00	8.00	—	6.50-12	—	—
14.00	S	5.50	5.50	4.62	4.00-12	5.25-12	4.00-12
	T	7.00	7.00	—	5.50-12	—	—
14.00	U	8.00	8.00	—	6.50-12	—	—
	S	5.50	5.50	4.62	4.00-12	5.25-12	4.00-12
16.00	T	7.00	7.00	—	5.50-12	—	—
	U	8.00	8.00	—	6.50-12	—	—

SERIES MT 2.00"-16.00" Bores MS7 End Lug Mount

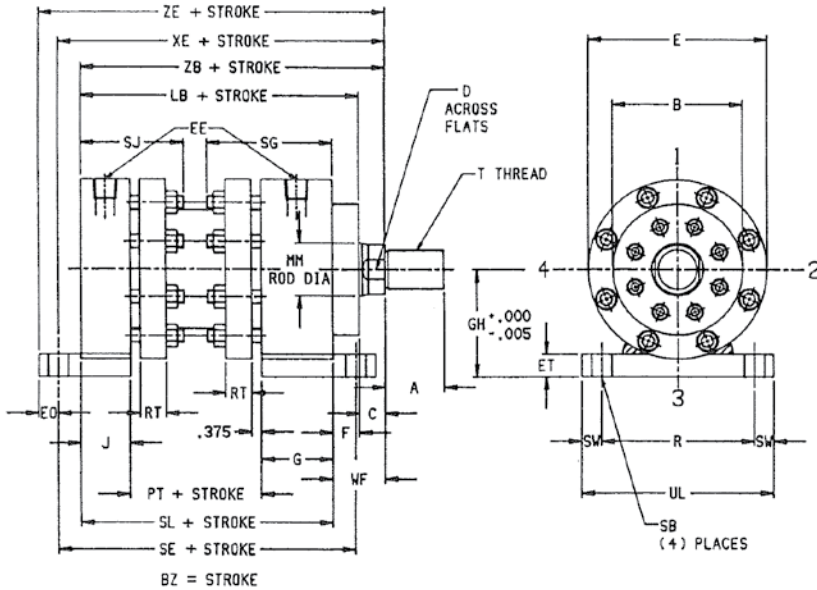

These Dimensions are Constant Regardless of Rod Diameter

BORE	B	BZ	C	E	EE		EQ	ET	F	G	GH	J	LB	PT	R	RT	SB
					SAE STRAIGHT THREAD	NPTF*											
2.00	3.25	1.38	0.81	4.12	#8 (1.750-16)	0.50	0.50	0.62	1.00	2.25	2.500	1.38	6.00	1.38	4.00	0.50	0.53
3.00	4.50	1.75	0.88	5.38	#12 (1.062-12)	0.75	0.62	0.75	1.12	2.62	3.250	1.75	7.25	1.75	4.62	0.75	0.66
4.00	5.00	2.38	1.00	6.88	#12 (1.062-12)	0.75	0.75	0.88	1.00	2.75	4.125	1.88	7.62	2.00	5.88	1.00	0.78
5.00	6.38	2.88	1.00	8.25	#12 (1.062-12)	0.75	0.88	1.00	1.00	3.00	4.875	2.12	8.62	2.50	6.75	1.25	0.91
6.00	7.38	3.25	1.00	9.62	#16 (1.312-12)	1.00	1.00	1.25	1.25	3.25	5.750	2.25	9.62	2.88	7.25	1.62	1.03
7.00	8.25	3.38	1.00	10.75	#16 (1.312-12)	1.00	1.00	1.25	1.25	3.25	6.375	2.25	9.75	3.00	8.25	1.75	1.03
8.00	9.75	3.25	1.12	12.38	#20 (1.625-12)	1.25	1.12	1.38	1.43	3.62	7.438	2.50	11.06	3.50	8.88	1.88	1.16
9.00	9.75	3.25	1.12	13.38	#20 (1.625-12)	1.25	1.12	1.38	1.43	3.62	7.938	2.50	11.31	3.75	9.88	2.00	1.16
10.00	10.75	3.25	1.00	15.50	#24 (1.875-12)	1.50	1.25	1.62	1.43	4.25	9.125	3.12	13.56	4.75	14.50	2.38	1.28
12.00	10.75	3.25	1.12	18.75	#24 (1.875-12)	1.50	1.50	1.88	1.43	4.50	11.000	3.62	15.19	5.62	17.00	2.75	1.53
14.00	12.00	4.00	1.00	21.50	#32 (2.500-12)	2.00	1.75	2.12	2.00	5.00	12.625	4.25	17.00	5.75	18.25	3.25	1.78
16.00	12.00	3.00	2.25	23.62	#32 (2.500-12)	2.00	2.00	2.38	2.00	6.00	14.000	5.00	19.00	6.00	22.00	3.75	2.06

*NPTF ports will be furnished unless SAE straight thread ports are specified.
Optional SAE 4-Bolt Flange Ports may be specified—Flange furnished by customer.

BORE	SE	SG	SJ	SL	SW	UL	WF	XE	ZB	ZE
2.00	6.75	3.47	2.59	5.00	0.50	5.00	1.81	7.69	6.81	8.19
3.00	7.88	4.22	3.34	6.12	0.62	5.88	2.00	9.00	8.12	9.62
4.00	8.38	4.78	3.91	6.62	0.75	7.38	2.00	9.50	8.62	10.25
5.00	9.62	5.41	4.53	7.62	0.88	8.50	2.00	10.62	9.62	11.50
6.00	10.88	6.19	5.19	8.38	1.69	10.62	2.25	11.88	10.62	12.88
7.00	11.50	6.69	5.69	8.50	1.69	11.62	2.25	12.25	10.75	13.25
8.00	12.62	6.81	5.69	9.62	2.19	13.25	2.56	13.69	12.19	14.81
9.00	12.88	6.81	5.69	9.88	2.19	14.25	2.56	13.93	12.43	15.06
10.00	15.62	7.91	6.78	12.12	1.25	17.00	2.43	16.19	14.56	17.43
12.00	17.25	8.78	7.91	13.75	1.62	20.25	2.56	18.19	16.31	19.69
14.00	19.00	9.66	8.91	15.00	2.12	22.50	3.00	20.00	18.00	21.75
16.00	21.00	10.03	9.03	17.00	2.00	26.00	4.25	23.25	21.25	25.25

CAUTION: Check for interference between rod attachment and mounting lug. Specify longer than standard "C" dimension if necessary.

NOTE: Lug mounted cylinders should be fastened at one end by using fitted bolts or by dowel pins. This will eliminate the tendency of the cylinder to shift when pushing or pulling.

NOTE: Dimensions are nominal except where specifically toleranced. Tolerances on "Plus Stroke" dimensions will vary slightly from dimensions shown due to manufacturing tolerances and tube compression.

STANDARD ROD END STYLES

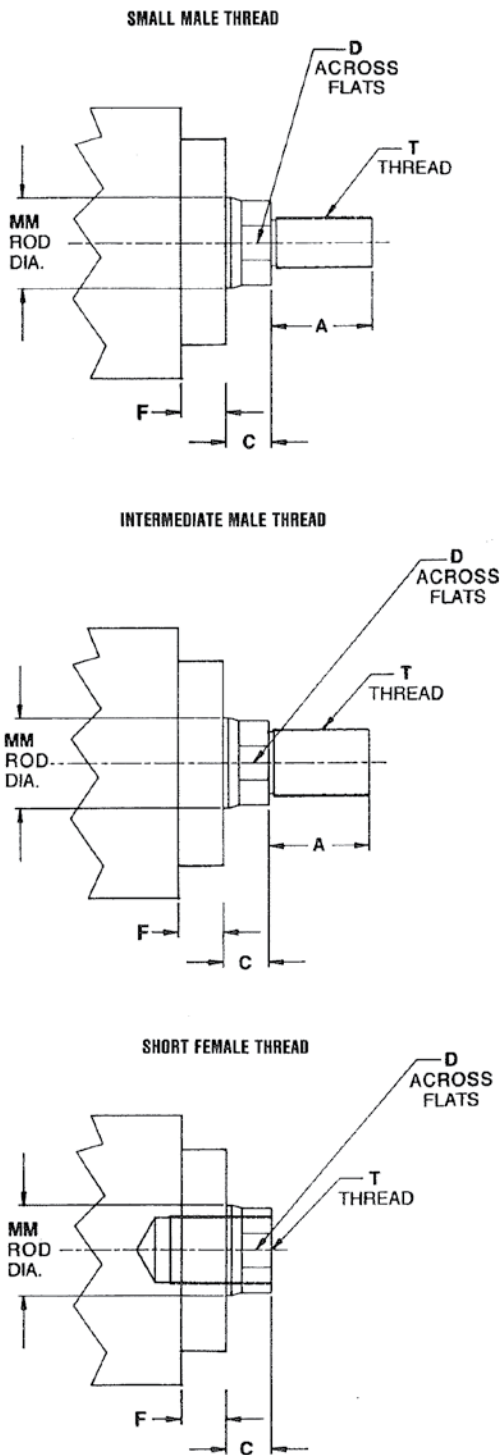

Dimensions are Affected by the Rod Diameter

MS7

BORE	ROD DIA. CODE	CYLINDER		A	D	T (THREAD)		
		MM ROD DIA.				SM SMALL MALE	IM INTER-MEDIATE MALE	SF SHORT FEMALE
2.00	F	1.00		1.12	.88	.75-16	.88-14	.75-16
	G	1.38		1.62	1.12	1.00-14	1.25-12	1.00-14
3.00	G	1.38		1.62	1.12	1.00-14	1.25-12	1.00-14
	H	1.75		2.00	1.50	1.25-12	1.50-12	1.25-12
4.00	J	2.00		2.25	1.69	1.50-12	1.75-12	1.50-12
	K	2.50		3.00	2.06	1.88-12	2.25-12	1.88-12
5.00	H	1.75		2.00	1.50	1.25-12	1.50-12	1.25-12
	J	2.00		2.25	1.69	1.50-12	1.75-12	1.50-12
6.00	K	2.50		3.00	2.06	1.88-12	2.25-12	1.88-12
	L	3.00		3.50	2.62	2.25-12	2.75-12	2.25-12
7.00	J	2.00		2.25	1.69	1.50-12	1.75-12	1.50-12
	K	2.50		3.00	2.06	1.88-12	2.25-12	1.88-12
8.00	L	3.00		3.50	2.62	2.25-12	2.75-12	2.25-12
	M	3.50		4.00	3.38	3.00-12	3.75-12	3.00-12
9.00	M	3.50		4.00	3.38	3.00-12	3.75-12	3.00-12
	N	4.00		4.50	4.25	3.50-12	4.25-12	3.50-12
10.00	N	4.00		4.50	4.25	3.50-12	4.25-12	3.50-12
	P	4.50		5.00	5.00	4.00-12	4.75-12	4.00-12
12.00	P	4.50		5.00	5.00	4.00-12	4.75-12	4.00-12
	R	5.00		5.50	6.00	5.00-12	5.75-12	5.00-12
14.00	R	5.00		5.50	6.00	5.00-12	5.75-12	5.00-12
	S	5.50		6.00	7.00	6.00-12	6.75-12	6.00-12
16.00	S	5.50		6.00	7.00	6.00-12	6.75-12	6.00-12
	T	7.00		8.00	8.00	7.00-12	7.75-12	7.00-12

TECHNICAL INFORMATION

PORT LOCATION

Numbers 1, 2, 3 and 4 around end view of cylinder drawings are for describing optional pipe port locations. Position 1 is standard. In many cases ports can be positioned at 2, 3 or 4 by rotating the heads at assembly. In other cases where it is undesirable to rotate the heads because of corresponding rotation of cylinder mountings, additional ports can usually be placed at positions 2, 3 or 4. Orders or inquiries should state port locations for rod and cap end heads, if other than standard. When changing port locations, careful attention should be paid to clearance between pipes, cylinder mountings, and the heads of any mounting screws.

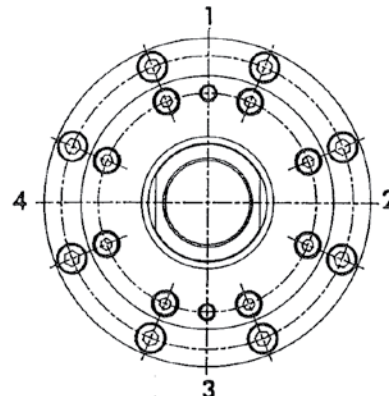

Standard ports will be supplied at Position 1. Orders should specify pipe port locations if other than standard. Optional ports and bossed ports are available. Refer to the charts below to select the appropriate port.

CAUTION:

Cylinders are intended for operation with standard ports. Oversize or additional ports may result in unacceptable fluid velocities within the cylinder. **Fluid velocities in the supply line in excess of 15 feet per second are not recommended.**

PORT SIZE

SERIES MT OPTIONAL PORTING

BORE	STANDARD SAE PORT	OVERSIZED BOSSED SAE	DIM. B	STANDARD NPTF PORT	OVERSIZED BOSSED PORT
2.00	#8 (.750-16)	#12 (1.062-12)	0.75	.50	.75
3.00	#12 (1.062-12)	#16 (1.312-12)	1.00	.75	1.00
4.00	#12 (1.062-12)	#16 (1.312-12)	1.00	.75	1.00
5.00	#12 (1.062-12)	#16 (1.312-12)	1.00	.75	1.00
6.00	#16 (1.312-12)	#20 (1.625-12)	1.12	1.00	1.25
7.00	#16 (1.312-12)	#20 (1.625-12)	1.12	1.00	1.25
8.00	#20 (1.625-12)	#24 (1.875-12)	1.38	1.25	1.50
9.00	#20 (1.625-12)	#24 (1.875-12)	1.38	1.25	1.50
10.00	#24 (1.875-12)	#32 (2.500-12)	1.62	1.50	2.00
12.00	#24 (1.875-12)	#32 (2.500-12)	1.62	1.50	2.00
14.00	#32 (2.250-12)		1.62	2.00	2.50
16.00	#32 (2.250-12)		1.62	2.00	2.50

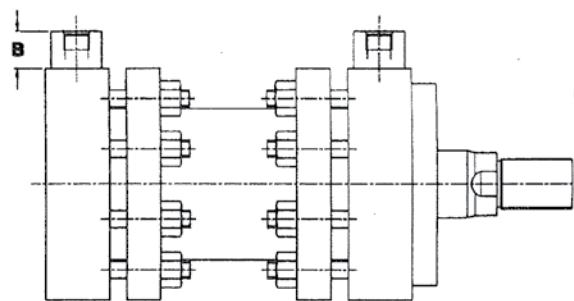

4-BOLT FLANGE PORTS

OPTIONAL SAE 4-BOLT FLANGE PORTS

BORE	PORT DIA.	GG	X	Q	W	AA	Z	B
2.00	N/A	N/A	N/A	N/A	N/A	N/A	N/A	N/A
3.00	.75	.88	.44	1.88	.94	.50	.375-16	1.06
4.00	.75	.88	.44	1.88	.94	.50	.375-16	1.06
5.00	.75	.88	.44	1.88	.94	.50	.375-16	1.06
6.00	1.00	1.03	.52	2.06	1.03	.56	.375-16	1.25
7.00	1.00	1.03	.52	2.06	1.03	.56	.375-16	1.25
8.00	1.25	1.19	.59	2.31	1.16	.62	.438-14	1.44
9.00	1.25	1.19	.59	2.31	1.16	.62	.438-14	1.44
10.00	1.50	1.41	.71	2.75	1.38	.81	.500-13	1.75
12.00	1.50	1.41	.71	2.75	1.38	.81	.500-13	1.75
14.00	2.00	1.69	.85	3.06	1.53	1.06	.500-13	2.00
16.00	2.00	1.69	.85	3.06	1.53	1.06	.500-13	2.00

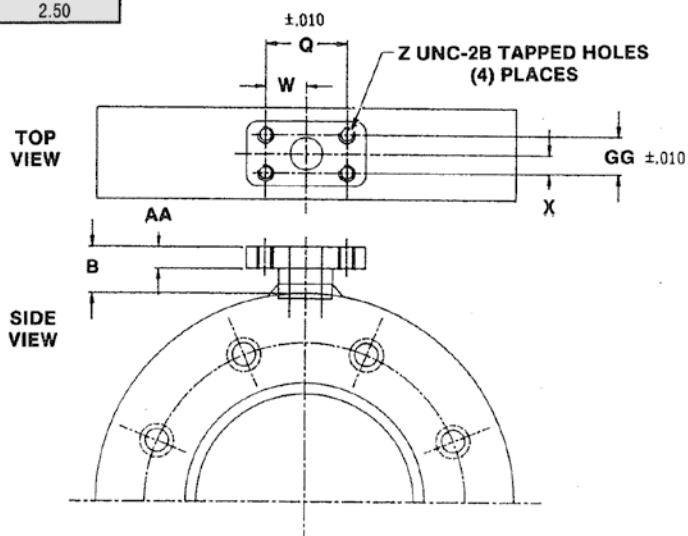

HYDRAULIC FORCE DATA

The formula for determining the force produced by a cylinder is

$$F = A \times \text{PSI}$$

Force (lbs.) = Cylinder Piston Area (sq. in.) X Line Pressure (lbs./sq. in.)

Chart C1 shows the force produced by specific cylinder bore sizes at various pressures. Forces not listed on the chart can be calculated by using the formula $F = A \times \text{PSI}$. An example of this formula follows:

EXAMPLE: Determine the thrust of a 14.00" bore cylinder operating at 1250 p.s.i. hydraulic line pressure.

$$F = 153.94 \times 1250 \quad F = 192,425$$

To select the proper bore size, first determine the force required for your particular application, then add a factor of five percent to allow for internal frictional losses.

Locate the total required force in Chart C1 in the column that matches your system's operating pressure. The bore size that produces the necessary total force at the desired operating pressure is the proper size for your application.

Chart C1 HYDRAULIC CYLINDER FORCE CHART*

Bore	Piston Area Sq. In.	PUSH STROKE Values are Pounds of Force						Gallons of Oil Consumed Per Inch of Travel
		250 PSI	500 PSI	750 PSI	1000 PSI	1500 PSI	2000 PSI	
2.00	3.14	786	1571	2357	3142	4713	6285	.0136
3.00	7.07	1767	3535	5302	7070	10605	14140	.0306
4.00	12.56	3143	6285	9428	12560	18860	25140	.0544
5.00	19.63	4910	9820	14730	19640	29460	39280	.0860
6.00	28.27	7068	14140	21200	28270	42400	56540	.1224
7.00	38.48	9623	19240	28870	38490	57740	76980	.1666
8.00	50.26	12570	25140	37700	50270	75400	100500	.2176
9.00	63.62	15905	31810	47715	63620	95430	127240	.2754
10.00	78.54	19640	39270	58900	78540	117800	157100	.3393
12.00	113.10	28280	56550	84820	113100	169600	226200	.4886
14.00	153.94	38480	76970	115455	153940	230910	307880	.6664
16.00	201.06	50270	100530	150800	201060	301590	402120	.8686

Chart C1A PULL STROKE

Rod Dia.	Rod Area Sq. In.	To determine pull stroke thrust or consumption, deduct the value for the rod diameter from the corresponding cylinder bore in Chart C1.						Gallons of Oil Consumed Per Inch of Travel
		250 PSI	500 PSI	750 PSI	1000 PSI	1500 PSI	2000 PSI	
1.00	.78	196	393	590	785	1175	1570	.0034
1.37	1.48	371	742	1113	1485	2230	2970	.0067
1.75	2.40	601	1202	1803	2405	3610	4810	.0104
2.00	3.14	786	1572	2357	3142	4715	6285	.0136
2.50	4.91	1225	2450	3682	4909	7350	9815	.0212
3.00	7.07	1767	3535	5302	7070	10605	14140	.0306
3.50	9.62	2405	4810	7216	9620	14435	19240	.0417
4.00	12.56	3142	6284	9426	12570	18850	25140	.0544
4.50	15.90	3976	7952	11930	15900	23860	31810	.0688
5.00	19.63	4909	9820	14730	19640	29450	39270	.0860
5.50	23.76	5940	11880	17820	23760	35640	47575	.1028
6.00	28.27	7068	14135	21200	28270	42400	56540	.1224
7.00	38.49	9623	19240	28870	38490	57740	76980	.1666
8.00	50.26	12565	25130	37695	50260	75390	100520	.2176

To obtain forces not given, multiply piston area times operating pressure.

*Forces given do not allow for frictional or other power losses.

1 U.S. Gallon = 231 Cubic Inches

PRESSURE RATINGS

Chart C2 shows the pressure ratings for Hanna Series MT Hydraulic Cylinders.

*Ratings are based on the ultimate tensile strength of the weakest component and smallest rod size.

Chart C2 HYDRAULIC CYLINDER RATING* (P.S.I.)

Bore	3:1 Factor of Safety	4:1 Factor of Safety
2.00	2650	2000
3.00	2650	2000
4.00	2650	2000
5.00	2650	2000
6.00	2650	2000
7.00	2650	2000
8.00	2650	2000
9.00	2650	2000
10.00	2650	2000
12.00	2650	2000
14.00	2650	2000
16.00	2250	1700

STROKE LIMITATION DATA

The rod diameter has to be capable of withstanding any compressive force developed by the cylinder working against the load. A piston rod diameter with adequate column strength to handle the compressive force of the application can be selected from the convenient pre-calculated chart below.

To use this chart find the force value, developed by the application, in the left column. Next, select the figure which resembles your application and then multiply "D" times the factor given in that figure. Finally, opposite the corresponding force value, find the value of "L" which is equal to, or greater than, the figure derived from factoring "D." Directly above is the rod diameter which is capable of withstanding the forces developed in the application.

NOTE: SEE APPLICATION FIGURES ON NEXT PAGE.

EXAMPLE: Cylinder Bore = 10.00" Operating PSI = 2000
 Force Value is 157,100
 Application—Resembles Fig. 2 End Lug Mtg.
 Stroke = 80"
 "L" = 0.7 x 80; L = 56
 Correct Rod Diameter = 4.00"

The total force is 157,000 lbs., and the value of "L" is 56 inches in this application. The smallest diameter rod capable of handling this situation is 4.00 inches.

If a stop tube is required for the application, be sure to include the stop tube length when determining the length of "D."

FORCE VALUE in pounds	VALUE OF "L" IN INCHES													
	PISTON ROD DIAMETER													
	1.00	1.38	1.75	2.00	2.50	3.00	3.50	4.00	4.50	5.00	5.50	6.00	7.00	8.00
400	85													
600	70	132												
800	60	114	184											
1000	54	102	165	215										
1300	47	90	145	188										
1700	41	78	127	165	258									
2100	37	71	114	149	232									
2500	34	65	104	136	213	304								
3000	31	58	95	124	192	280	381							
4000	27	51	83	108	162	242	330	430						
5000	24	46	74	96	150	217	295	385						
6000	22	42	67	89	137	198	269	352	443					
8000	19	36	58	76	119	172	233	305	384	475				
10000	17	32	52	68	106	153	209	273	344	426	514			
12000	15	29	48	62	97	139	190	249	314	328	468	559	761	
16000	13	26	42	54	84	121	165	215	272	316	407	484	659	861
20000		23	38	48	76	109	149	193	243	301	365	433	590	770
30000		18	31	39	61	89	120	153	198	245	297	354	481	629
40000			27	34	53	77	104	136	172	213	257	306	417	545
50000			23	31	48	69	93	122	153	190	230	274	373	487
60000			21	28	44	63	85	111	140	174	210	250	340	445
80000				24	38	54	74	96	122	143	192	217	295	385
100000					34	48	66	86	109	132	163	194	264	344
120000					31	44	60	79	100	121	142	177	240	314
140000						41	56	73	92	112	135	164	223	291
160000						38	52	63	86	105	129	153	209	272
200000							47	61	77	93	115	137	187	244
250000							42	54	69	84	103	123	167	218
300000													152	199
350000													141	184
400000													131	172
500000													118	154

If a stop tube is required for the application, be sure to include the stop tube length when determining the length of "D."

STOP TUBE DATA

Long stroke cylinders can be subjected to a buckling action and excessive bearing wear due to the weight of the exposed rod. To reduce wear a stop tube is recommended.

All cylinders cushioned and non-cushioned are supplied with single piston construction. General construction of cylinder stop tube is illustrated below.

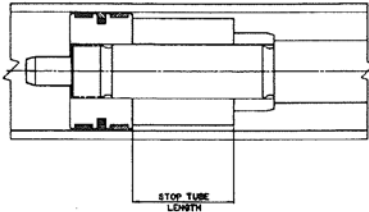

To determine if a stop tube is required, find the total value of "L" using the stroke limitation chart. Compare this value with the stop tube chart. If the value of "L" exceeds 40 inches, you can find the recommendation for stop tube length at the bottom of the chart.

EXAMPLE PROBLEM:
 Cylinder Model MS7-MT-NC-8-45-NSM-1A
 Pressure—1500 PSI
 End Lug Mount—Horizontal

From the description, the cylinder falls into Fig. 3. To determine the value of "L":

$$2 \times \text{Stroke } (2 \times 45) = 90$$

$$\text{Total Value of "L" } = 90$$

Looking this up on the chart, you'll find a recommended stop tube length of 6 inches.

The amount of stop tube will increase the stroke-plus dimensions of the cylinder by the same value. Add length of the stop tube to the value of "L" and recheck column strength on stroke limitation chart.

STOP TUBE CHART

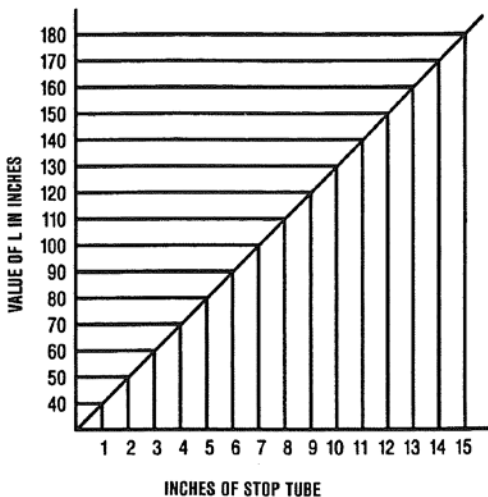

ROD END CONNECTION	
FIXED & WELL GUIDED	FIG. 1 "L" = 0.5 X D
PIVOTED AND WELL GUIDED	
	FIG. 2 "L" = 0.7 X D
SUPPORTED NOT WELL GUIDED	
	FIG. 3 "L" = 2 X D
PIVOTED AND WELL GUIDED	
	FIG. 4 "L" = 0.7 X D FOR LONG STROKE SUPPORT HEAD
	FIG. 5 HEAD NOT SUPPORTED "L" = D
	FIG. 6 "L" = 0.7 X D
	FIG. 7 "L" = D
	FIG. 8 "L" = D

MOUNTING ACCESSORIES

These are standard accessories matched to bore size and piston rod code. The Clevis Bracket (Item MB) fits the cap end of Model MP1. The Bracket (Item B) fits the piston Rod Clevis with the same number (i.e. B-7 Bracket fits V-7 Rod Clevis). The Clevis Pin (Item PC) is furnished with Model MP1 and fits the Clevis Bracket (Item MB). Specify if additional pins are required. If you require accessories other than standard for that bore size or piston rod, specify the item number on your order.

*** CAUTION:**

Accessory load rating may be lower than maximum force available from cylinder. Accessories load ratings are in pounds. Before specifying, compare maximum operating pull force in pounds developed by cylinder with load rating of accessory. Accessory load rating is the maximum recommended operating load for that accessory.

Rod Clevis

Use with Item B Brackets and Item P Pin.

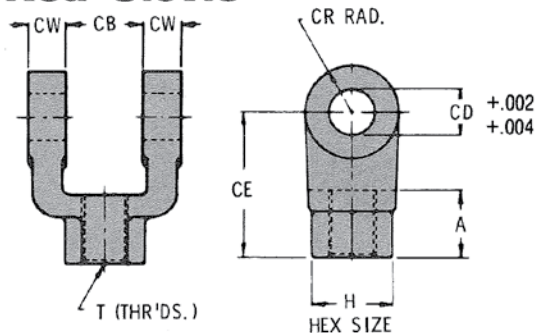

ROD CLEVIS ITEM NO.	PISTON ROD CODE	A	CB	CD	CE	CR	CW	H	T	*LBS. CAPACITY
V-2	F	1.12	1.25	.75	2.38	.88	.62	1.25	.75-16	14,000
V-3	G	1.62	1.50	1.00	3.12	1.12	.75	1.75	1.00-14	22,500
V-4	H	2.00	2.00	1.37	4.12	1.62	1.00	2.00	1.25-12	41,250
V-5	J	2.25	2.50	1.75	4.50	2.00	1.25	2.75	1.50-12	57,000
V-6	K	3.00	2.50	2.00	5.50	2.25	1.25	3.00	1.88-12	75,000
V-7	L	3.50	3.00	2.50	6.50	2.88	1.50	3.50	2.25-12	112,500
V-8	M	3.50	3.00	3.00	6.75	3.12	1.50	3.88	2.50-12	135,000
V-10	P	4.50	4.00	3.50	8.50	3.88	2.00	5.00	3.25-12	210,000
V-12	S	5.50	4.50	4.00	10.00	4.38	2.25	6.19	4.00-12	270,000

Rod Eye

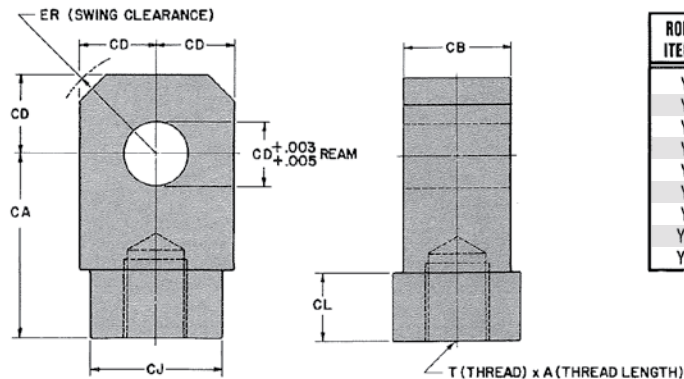

ROD EYE ITEM NO.	PISTON ROD CODE	A	CA	CB	CD	CJ DIA.	CL	ER	T	*LBS. CAPACITY
Y-2	F	1.12	2.06	1.25	.75	-	-	1.12	.75-16	12,500
Y-3	G	1.62	2.81	1.50	1.00	-	-	1.44	1.00-14	20,250
Y-4	H	2.00	3.44	2.00	1.37	-	-	2.00	1.25-12	37,000
Y-5	J	2.25	4.00	2.50	1.75	-	-	2.50	1.50-12	59,000
Y-6	K	3.00	5.00	2.50	2.00	3.25	2.50	2.88	1.88-12	67,500
Y-7	L	3.50	5.81	3.00	2.50	4.00	2.81	3.56	2.25-12	101,250
Y-8	M	3.50	6.12	3.00	3.00	5.00	2.50	4.25	2.50-12	121,500
Y-10	P	4.50	7.62	4.00	3.50	6.12	3.50	5.00	3.25-12	189,000
Y-12	S	5.50	9.12	4.50	4.00	7.00	4.50	5.75	4.00-12	243,000

Pin

Use with Item V Rod Clevis, Item Y Rod Eye and Item B Brackets.

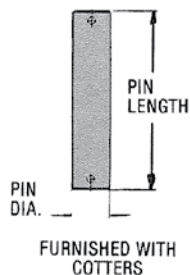

PIN ITEM NO.	LENGTH	DIAMETER	*LBS. CAPACITY
P2	3.09	.75	13,800
P3	3.60	1.00	24,500
P4	4.66	1.37	46,500
P5	5.66	1.75	75,150
P6	5.72	2.00	98,150
P7	6.94	2.50	153,400
P8	7.19	3.00	220,900
P10	9.31	3.50	300,650
P12	10.31	4.00	307,850

Piston Rod Stud

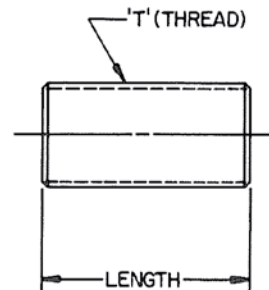

ITEM NO.	T	LENGTH
Stud 2	.75-16	2.25
Stud 3	1.00-14	3.25
Stud 4	1.25-12	4.00
Stud 5	1.50-12	4.50

Brackets

Use with Item V Rod Clevis and Item P Pin.

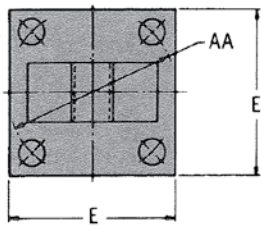

BRACKET ITEM	AA	CB	CD	DD	DE	E	F	FL	LR	M	MR	*LBS. CAPACITY
B-2	3.60	1.25	.750	.56	.88	3.50	.62	1.88	.88	.75	.88	6,300
B-3	4.60	1.50	1.000	.69	1.38	4.50	.75	2.25	1.25	1.00	1.25	10,000
B-4	5.40	2.00	1.375	.69	1.75	5.00	.88	3.00	1.75	1.38	1.75	19,250
B-5	7.00	2.50	1.750	.94	2.25	6.50	.88	3.12	2.12	1.75	2.12	21,200
B-6	8.10	2.50	2.000	1.06	2.56	7.50	1.00	3.50	2.38	2.00	2.38	24,500
B-7	9.30	3.00	2.500	1.19	3.12	8.50	1.00	4.00	2.94	2.50	2.94	25,000
B-8	10.60	3.00	3.000	1.31	3.25	9.50	1.00	4.25	3.19	2.75	3.19	22,500
B-10	13.60	4.00	3.500	1.81		12.62	1.69	7.25	3.62	3.50	3.62	58,500
B-12	16.19	4.50	4.000	2.06		14.88	1.94	7.75	4.12	4.00	4.12	73,250

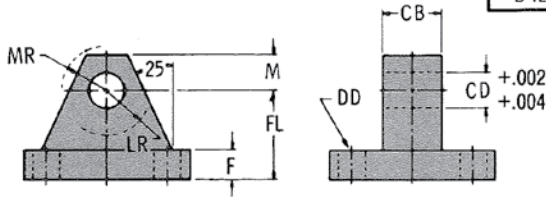

Linear Alignment Coupler

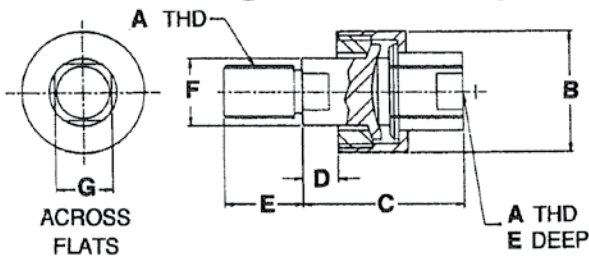

PART NO.	A	B	C	D	E	F	G	H	MAX. PULL LOAD
S-2	.750-16	1.75	2.31	0.50	1.12	0.94	0.81	1.12	8,750
S-3	1.000-14	2.50	2.94	0.53	1.62	1.34	1.16	1.62	16,125
S-4	1.250-12	2.50	2.94	0.53	1.62	1.34	1.16	1.62	19,600
S-5	1.500-12	3.25	4.38	0.88	2.25	1.94	1.75	2.38	34,000
S-6	1.875-12	3.75	5.62	1.00	3.00	2.94	—	—	41,250
S-7	2.250-12	6.75	6.38	1.00	3.50	2.75	2.38	2.88	99,250

Universal Spherical Rod Eyes

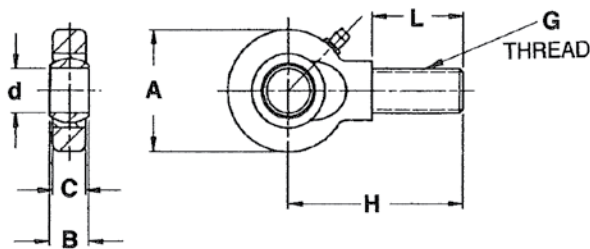

Male

PART NO.	d	B	H	G	L	A	C	LBS. CAPACITY
UMY-12	0.75	0.66	3.00	.750-16	1.56	2.06	0.56	7500
UMY-20	1.25	1.09	4.56	1.250-12	2.56	3.31	0.94	20700
UMY-24	1.50	1.31	5.41	1.500-12	3.06	4.00	1.12	29800
UMY-28	1.75	1.53	6.31	1.750-12	3.56	4.62	1.31	40800
UMY-32	2.00	1.75	7.19	2.000-12	4.06	5.25	1.50	52800
UMY-36	2.25	1.97	8.12	2.250-12	4.50	5.88	1.69	66800
UMY-40	2.50	2.19	9.00	2.500-12	5.00	6.50	1.88	82800

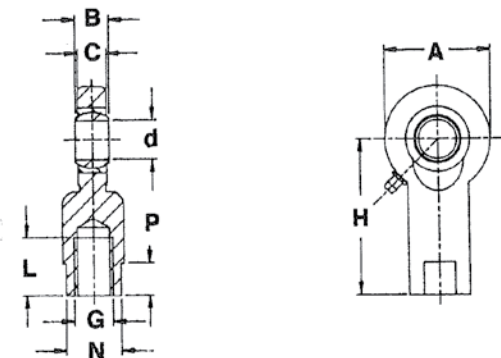

Female

PART NO.	d	B	H	G	L	A	N	C	P	LBS. CAPACITY
UFY-12	0.75	0.66	3.00	.750-16	1.12	2.06	1.19	0.56	0.62	7500
UFY-20	1.25	1.09	4.56	1.250-12	1.81	3.31	1.88	0.94	0.75	20700
UFY-24	1.50	1.31	5.41	1.500-12	2.12	4.00	2.31	1.12	1.00	29800
UFY-28	1.75	1.53	6.31	1.750-12	2.44	4.62	2.75	1.31	1.19	40800
UFY-32	2.00	1.75	7.19	2.000-12	2.75	5.25	3.12	1.50	1.19	52800
UFY-36	2.25	1.97	8.12	2.250-12	3.00	5.88	3.38	1.69	1.38	66800
UFY-40	2.50	2.19	9.00	2.500-12	3.25	6.50	3.69	1.88	1.38	82800

Male Rod Eye

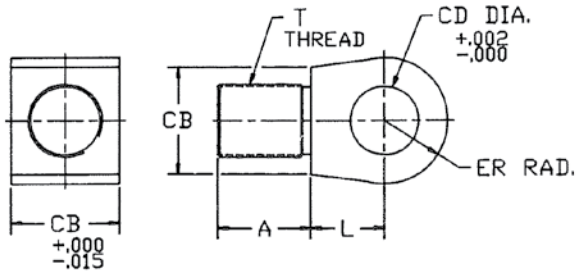

ROD EYE ITEM NO.	A	CB	CD	ER	T	L	*LBS. CAPACITY
MY-2	.88	1.25	.752	.62	.75-16	.88	5,000
MY-3	1.25	1.50	1.252	1.12	1.00-14	1.38	9,300
MY-4	1.62	2.00	1.377	1.25	1.25-12	1.50	14,900
MY-5	1.88	2.25	1.502	1.38	1.50-12	1.62	22,250
MY-6	2.38	2.75	1.752	1.62	1.88-12	1.88	36,000
MY-8	2.88	3.25	2.002	1.88	2.25-12	2.12	53,200
MY-10	3.38	3.75	2.502	2.38	2.50-12	2.62	66,700
MY-12	4.00	4.50	3.002	2.88	3.00-12	3.12	97,300
MY-14	5.50	6.00	3.502	3.38	4.00-12	3.62	176,000
MY-16	6.50	7.50	4.252	4.00	5.00-12	4.25	280,000

Clevis Brackets

Use with MP1 Mount.

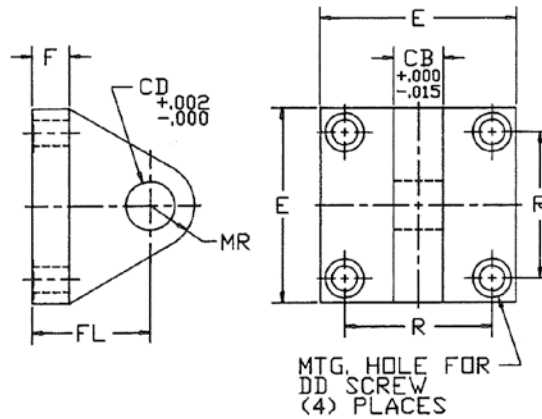

BRACKET ITEM NO.	CB	CD	OD	E	F	FL	MR	R	*LBS. CAPACITY
MB-2	1.00	.752	.38	3.00	.56	1.75	.62	2.25	7,350
MB-3	1.25	1.252	.62	5.00	.94	3.00	1.12	3.75	18,562
MB-4	1.25	1.377	.75	6.00	1.19	3.88	1.25	4.50	21,000
MB-5	1.25	1.502	1.00	7.00	1.44	4.62	1.38	5.00	23,625
MB-6	1.50	1.752	1.25	8.25	1.69	5.62	1.62	6.00	33,525
MB-8	3.00	2.002	1.50	10.00	1.94	6.88	1.88	7.25	79,200
MB-10	3.50	2.502	1.75	13.25	2.19	8.75	2.38	10.00	118,650
MB-12	4.50	3.002	2.00	15.75	2.44	10.25	2.88	12.00	186,300
MB-14	5.00	3.502	2.00	18.00	2.44	11.25	3.38	14.25	231,707
MB-16	6.00	4.252	2.50	20.50	2.94	12.50	4.00	16.00	354,387

Clevis Pin

Use with Item MY Rod Eye and Item MB Clevis Bracket. Included with MP1 Mount.

PIN ITEM NO.	LENGTH	DIAMETER	*LBS. CAPACITY
PC-2	3.25	.750	13,800
PC-3	3.75	1.250	38,350
PC-4	4.00	1.375	46,500
PC-5	4.75	1.500	55,200
PC-6	5.50	1.750	75,150
PC-8	7.00	2.000	98,150
PC-10	8.00	2.500	153,400
PC-12	10.50	3.000	220,900
PC-14	11.50	3.500	300,650
PC-16	13.50	4.250	443,000

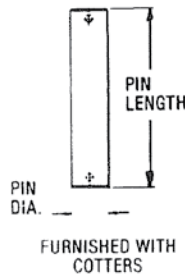

*** CAUTION:**

Accessory load rating may be lower than maximum force available from cylinder. Accessories load ratings are in pounds. Before specifying, compare maximum operating pull force in pounds developed by cylinder with load rating of accessory. Accessory load rating is the maximum recommended operating load for that accessory.

Self-Aligning Rod End Coupling

Hanna's Self-Aligning Rod End Coupling permits fast, easy assembly, disassembly, installation and servicing. Precision-machined, two-piece steel construction provides close radial alignment between piston rod end and machine member.

Allowing for radial movement increases seal and bearing life within the cylinder by eliminating much of the side load. High-tensile alloy steel, socket head cap screws and all-steel construction are designed to take full cylinder load with a factor of safety.

The Self-Aligning Rod End Coupling is used in conjunction with Hanna's RC rod end.

A Weld Plate is an added accessory for use with the Self-Aligning Rod End Coupling. It eliminates lay-out, drilling and tapping each hole to match the coupling on your machine. The hole in the center of the Weld Plate is accurately drilled for a locating pin for fast, close positioning to the machine prior to welding.

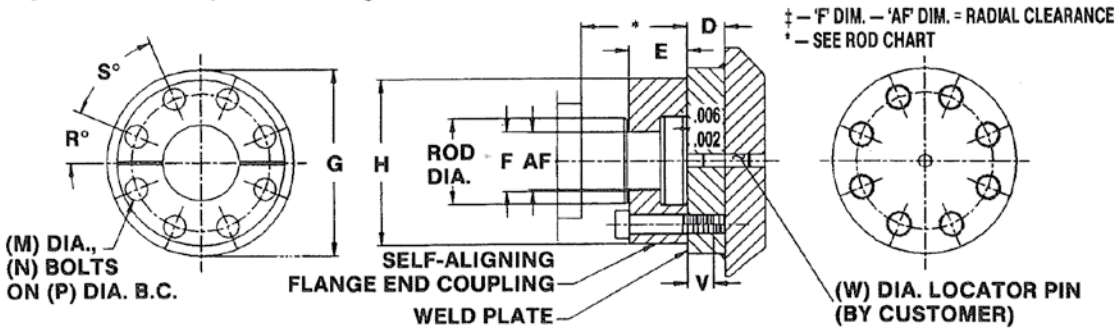
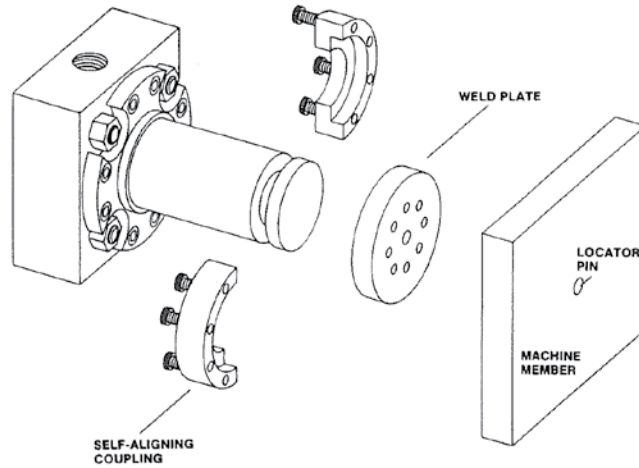

COUPLING NO.	ROD DIA. MM	AF ±	E	F ±	H	M	N	P	R	S	V	WELD PLATE NO.	D	G	W PIN DIA.	BOLT TORQ. FT. LB.
CP-100	1.00	.688	.62	.750	2.00	.250-20	6	1.50	30	60	.375	WP-100	.500	2.50	.25	13
CP-138	1.38	.875	.69	.938	2.50	.312-18	6	2.00	30	60	.562	WP-138	.625	3.00	.25	25
CP-175	1.75	1.12	.88	1.19	3.00	.375-16	8	2.38	22.5	45	.625	WP-175	.750	3.50	.25	45
CP-200	2.00	1.38	1.25	1.44	3.50	.375-16	12	2.69	15	30	.750	WP-200	.875	4.00	.38	45
CP-250	2.50	1.75	1.38	1.88	4.25	.500-13	8	3.44	22.5	45	.875	WP-250	1.00	5.00	.38	80
CP-300	3.00	2.25	1.88	2.38	5.00	.500-13	12	4.00	15	30	.875	WP-300	1.00	5.50	.38	80
CP-350	3.50	2.50	2.00	2.62	5.88	.625-11	12	4.69	15	30	1.00	WP-350	1.12	6.50	.38	200
CP-400	4.00	3.00	2.00	3.12	6.38	.625-11	12	5.19	15	30	1.00	WP-400	1.12	7.00	.38	200
CP-450	4.50	3.50	2.38	3.62	6.88	.750-10	8	5.69	22.5	45	1.12	WP-450	1.25	7.50	.38	350
CP-500	5.00	3.88	2.50	4.00	7.38	.625-11	12	6.19	15	30	1.00	WP-500	1.38	8.00	.38	200
CP-550	5.50	4.38	3.12	4.50	8.25	.750-10	12	6.88	15	30	1.38	WP-550	1.50	9.00	.38	350

NOTE: FOR LARGER COUPLING SIZES, CONSULT FACTORY

RC ROD END DIMENSIONS

ROD STYLE	ROD CODE	ROD DIA MM	AC	AD	AE	AF DIA
RC-100	F	1.00	1.62	.938	.375	.688
RC-138	G	1.38	2.25	1.06	.375	.875
RC-175	H	1.75	2.75	1.31	.500	1.12
RC-200	J	2.00	3.12	1.69	.625	1.38
RC-250	K	2.50	4.00	1.94	.750	1.75
RC-300	L	3.00	4.50	2.44	.875	2.25
RC-350	M	3.50	4.50	2.69	1.00	2.50
RC-400	N	4.00	5.00	2.69	1.00	3.00
RC-450	P	4.50	5.50	3.19	1.50	3.50
RC-500	R	5.00	6.00	3.19	1.50	3.88
RC-550	S	5.50	6.50	3.94	1.88	4.38

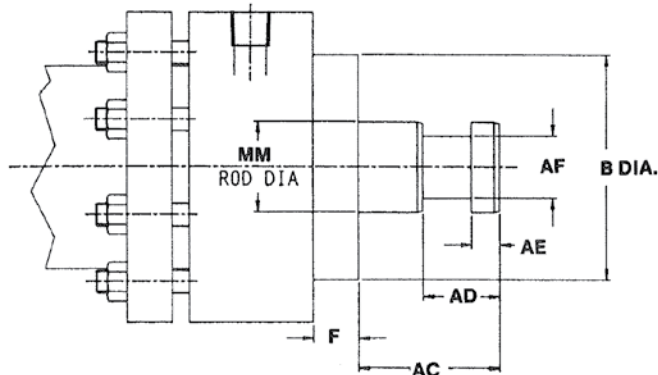

ELECTRONIC & ELECTRICAL CONTROLS

Proximity Switches

Hanna offers GO Model 75 and Model 77 proximity switches for mounting on Series MT cylinders through 8.00" bores.

The GO switch uses three magnets to move a common terminal between two contacts. The primary magnet is held in the retracted position, with one of its magnetic poles attracted to the unlike pole of the center magnet. At the same time, the bias magnet is being repelled by the like pole of the bias magnet. In this mode (Figure 1), the rod connected to the primary magnet keeps the common terminal in the Normally Closed (N/C) contact position.

When a ferrous actuator enters the sensing area of the switch (Figure 2), the magnetic attraction of the primary magnet to the center magnet is weakened. The primary magnet moves toward the actuator, pulling the connecting rod forward and moving the common terminal to the Normally Open (N/O) contact position.

SPECIFICATIONS

Size—(Model 75): 5/8" dia. x 4-5/16" long, with 5/8"-18 NF x 2-13/16" threads.

Size—(Model 77): 3/4" dia. x 5-13/16" long, with 3/4"-16 UNF x 2-7/8" threads.

Sensing Distance: 0.100" end sensing.

Differential: Approximately .040".

Response Time: 8 milliseconds.

Temperature Rating: -40°F to +221°F.

Contacts: Single Pole, Double Throw, Form C
Silver cadmium oxide, gold flashed.

Rating: 2 amp @ 240 VAC, 50 mA @ 24VDC (CSA only). 250 VDC @ .5 amp resistive (UL only).

Housing: Stainless steel.

Conduit Outlet: 1/2"—14 NPT. One location.

Repeatability: 0.002" typical.

ORDERING INFORMATION

GO Models 75 and 77 Proximity Switches are available on Hanna's Series MT Mill-Type Hydraulic Cylinders 2.00" through 8.00" bores. Consult factory for availability and mounting on bore sizes over 8.00".

Switches will be mounted at the factory according to customer specified locations. Specify mounting position of switches and pipe port location, referring to numbered positions on end view of cylinder as shown.

Position location for both the Front Head and Blind Head is determined by viewing the cylinder at the Rod End. Position 5 is at back face of Blind Head.

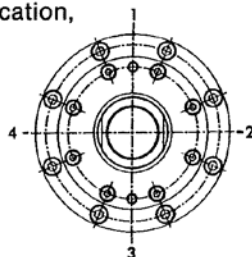

Figure 1

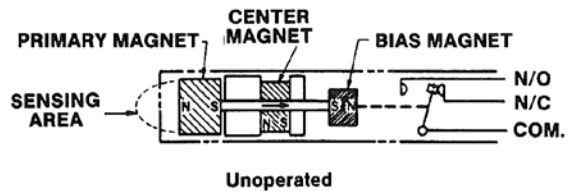
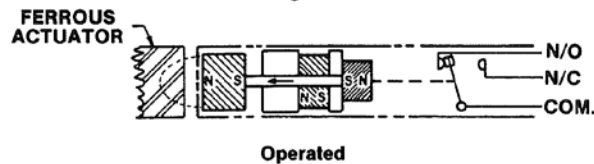
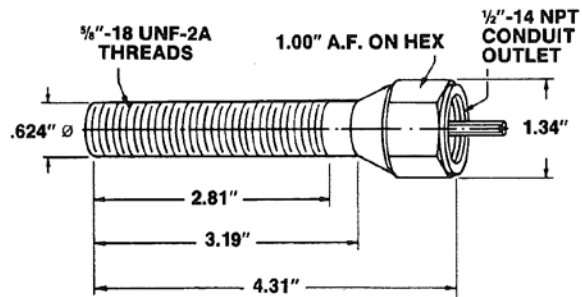

Figure 2



Model 75



Model 77

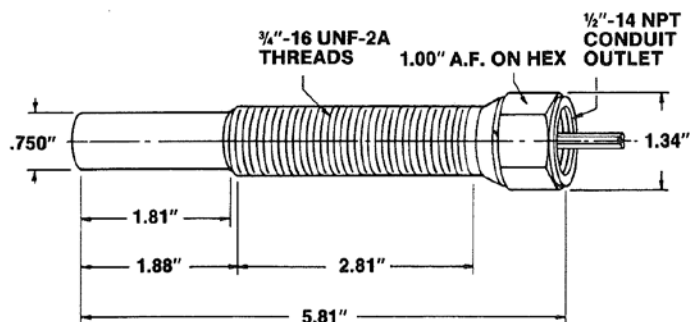

Electronic Feedback Device

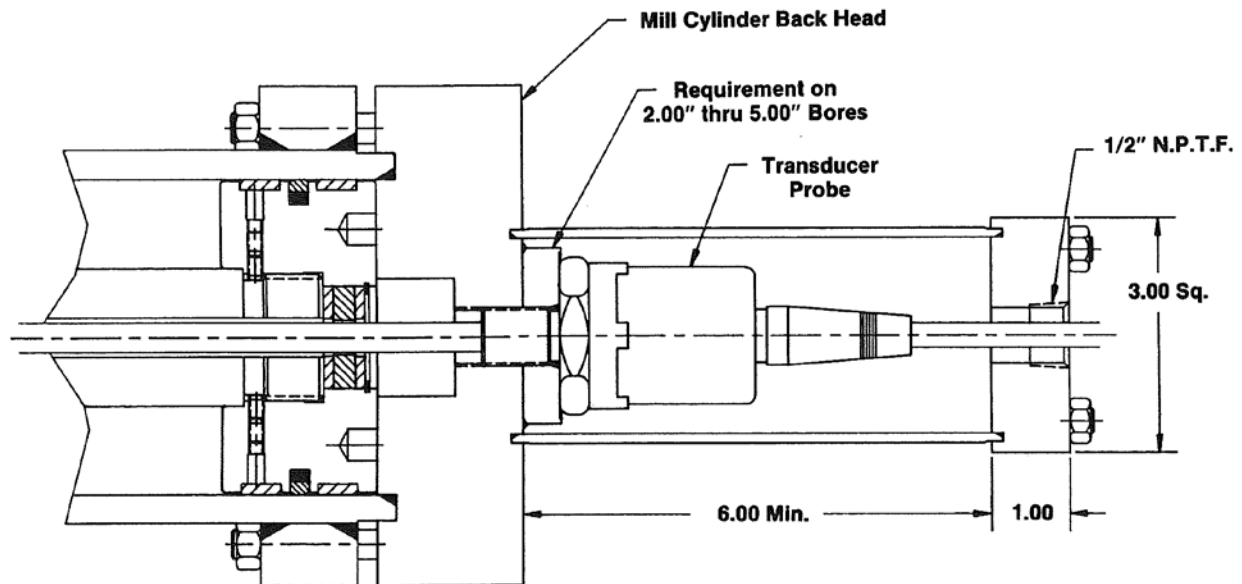

Hanna's Electronic Feedback Device is ideal for a wide range of mill-type cylinder applications, including edge guiding on coil processing equipment, screwdown cylinder roll positioning, forming and bending of precise metal shapes, rapid acceleration and deceleration of large masses, and other applications where precise control is required. Positional accuracy of ± 0.001 and repeatability of ± 0.001 are easily obtained in digital systems. Analog responses on positions less than .010 are common.

Standard mountings for Series MT cylinders equipped with the Electronic Feedback Device are MT4 Intermediate Fixed Trunnion, ME5 Head Flange and MS7 End Lugs. MT cylinders with mounting styles MP1 Fixed Double Ear Clevis, MP3 Fixed Single Ear Clevis and MPU3 Spherical Bearing Mount can be custom modified to accept the feedback device. Please consult Factory.

The Electronic Feedback Device is available on all bore sizes from 2.00" through 16.00". Hanna can provide Series MT cylinders with the device installed as a complete package. We can also supply MT cylinders fully prepared to accept customer-installed devices.

INSTALLATION, OPERATION AND MAINTENANCE DATA

INSTALLATION:

The pipe ports of cylinders are sealed with plastic plugs. The plugs protect the precision internal parts by sealing out damaging dirt and grit. Do not remove port seals until ready to connect piping. To protect cylinders, clean all pipes and pipe fittings of dirt, scale, and thread chips. A filter is recommended to keep the operating fluid free of foreign matter.

Accurate mounting and alignment are essential for proper cylinder performance. By eliminating side loading, packing and bearing life will be increased. Mounting surfaces should be straight, bearings for pin and trunnion mounting must be in line.

Dirt or abrasive matter adhering to the piston rod may cause excessive wear to the piston rod and gland. For best results, protect the cylinder from such dirt. A piston rod protective shield is ideal for this purpose.

OPERATION:

Needle valves in cylinder head and cap of adjustable cushioned cylinders permit regulation of cushioning effect. Adjust needle valve with an Allen wrench, rotating clockwise to increase cushioning and counter-clockwise to decrease cushioning effect. Cushion adjustment needles require only about one to one and a half turn adjustment. Speed control valves are essential for obtaining the best cushioning operation. A proper balance of cushion needle and flow control valve adjustment should result in a smooth stop with no bouncing.

MAINTENANCE:

Parts which may need replacement in the course of normal use are the rod wiper and the packings for the piston rod.

The need for replacement of the piston rod packing will become evident through the escaping of fluid around the gland.

To replace rod wiper or rod packings, remove the gland from the cylinder. Remove worn rod wiper and rod packing. To reassemble, slip new rod wiper and rod packing into grooves. Care should be exercised not to nick the lips of the packings. Be sure to retorque gland screws to the specified torque for the cylinder. (See torque chart below.)

It is recommended that new "O" rings be installed each time the cylinder is disassembled for maintenance. This applies to tube and gland "O" rings. The cushion needle valve "O" rings should also be replaced if these parts are disassembled. When reassembling, be sure to apply proper bolt torque. (See torque chart below.)

If the cushion action of the cylinder fails, check to determine if the cushion sleeve has been worn on its outside diameter, and if foreign particles have become lodged between the face of the sleeve and the cylinder head bore.

If the cylinder fails to perform the job for which it is ordered, check the following items: 1. That the correct cylinder diameter has been chosen to do the job required. 2. That there is adequate line pressure at the cylinder, under both static and dynamic conditions. 3. That the piston rod is aligned correctly with the load it is pushing or pulling. 4. That the piston packings or the piston rod packings are not worn, allowing pressure to escape.

Replacement parts can be furnished quickly if you will indicate the serial number of the cylinder as shown on the name plate, and the part name and number, as shown. The cylinder illustrated is for reference purposes only, and does not represent any particular model.

FASTENER TORQUES

BORE	HEAD BOLT TORQUE		GLAND SCREW TORQUE	
	BOLT SIZE	TORQUE	SCREW SIZE	TORQUE
2.00	.312-18	25 ft.-lbs.	.312-18	25 ft.-lbs.
3.00	.312-18	25	.312-18	25
4.00	.375-16	45	.375-16	45
5.00	.500-13	100	.437-14	60
6.00	.625-11	200	.500-13	100
7.00	.625-11	200	.500-13	100
8.00	.625-11	200	.625-11	200
9.00	.625-11	200	.625-11	200
10.00	.750-10	350	.625-11	200
12.00	.875-9	575	.625-11	200
14.00	.875-9	575	.750-10	350
16.00	1.000-8	950	.750-10	350

SEAL KITS

All cylinders are fully field identifiable, including packing option codes.

NAMEPLATE CODE EXAMPLE

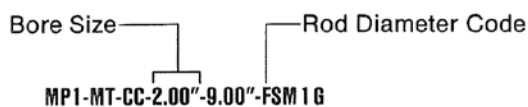

PISTON ROD KITS

Ordering Example:

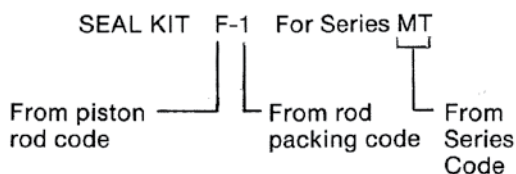

Order by Piston Rod Packing Code, Rod Diameter Code, and Cylinder Series Code from nameplate as outlined.

PISTON PACKING KITS

Ordering Example:

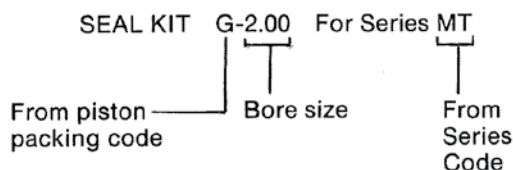

Order by Piston Packing Code, Bore Size, and Cylinder Series Code from nameplate as outlined.

- 1 (STANDARD)
Temperature Range -20° F to +200° F
Buna-N O-Rings, Polyurethane Rod Packing and Polyurethane Wiper.
- 3 (OPTIONAL)
Temperature Range -20° F to +400° F
Viton O-Rings, Viton Rod Packing, Viton Wiper.

- A Temperature Range -20° F to +200° F
Polyurethane U-Cup Seal with Buna Expander, Wear Strip, Buna Tube Seals.
- B Temperature Range -20° F to +400° F
Viton U-Cup Seal with Viton Expander, Wear Strip, Viton Tube Seals.
- G Temperature Range -20° F to +200° F
Piston Wear Strip(s), Filled Teflon seal w/Buna-N Expander, Buna-N Tube Seals.
- H Temperature Range -20° F to +400° F
Piston Wear Strip(s), Filled Teflon Seal w/Viton Expander, Viton Tube Seals.

CYLINDER WEIGHTS

BORE	BASE WEIGHT AT ZERO STROKE	BODY WEIGHT PER INCH OF STROKE	ROD SIZE	ROD WEIGHT PER INCH OF STROKE
2.00	18 lbs.	.50 lbs.	1.00	.22 lbs.
3.00	41	.72	1.38	.42
4.00	70	1.20	1.75	.68
5.00	124	1.88	2.00	.89
6.00	178	2.12	2.50	1.39
7.00	226	3.33	3.00	2.00
8.00	333	3.77	3.50	2.72
9.00	397	4.22	4.00	3.56
10.00	648	4.67	4.50	4.50
12.00	1062	11.56	5.00	5.56
14.00	1575	13.34	5.50	6.72
16.00	2188	15.11	6.00	8.00
			7.00	10.89
			8.00	14.22

PARTS LIST

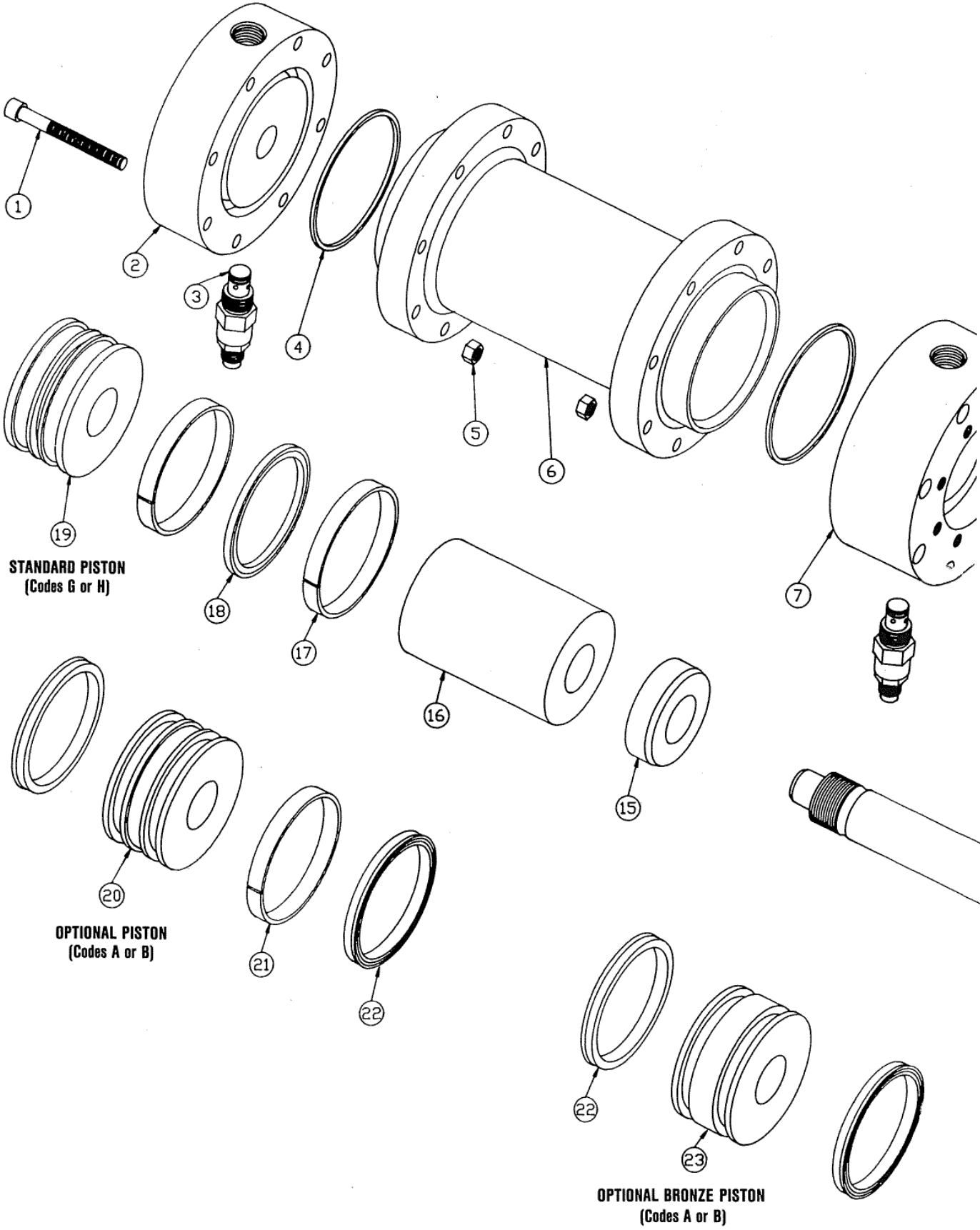

STANDARD PISTON
(Codes G or H)

OPTIONAL PISTON
(Codes A or B)

OPTIONAL BRONZE PISTON
(Codes A or B)

When ordering replacement parts, identify Model Number, Serial Number and Part Number, as shown below.

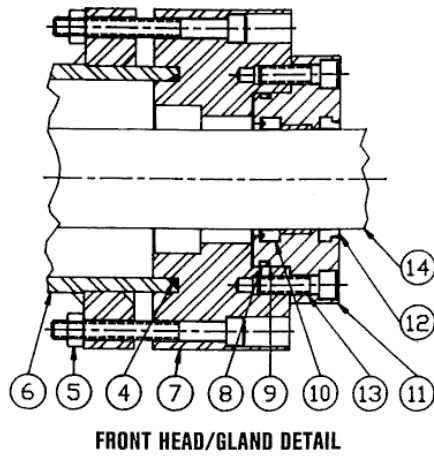

PART NO.	NO. REQ'D.	DESCRIPTION
1	**	Cap Screw
2	1	Back Head
3	2	Cushion Valve
4*	2	O-Ring
5	**	Nut
6	1	Tube
7	1	Front Head
8*	1	O-Ring
9*	1	Back Up
10*	1	Rod Packing
11	1	Gland
12*	1	Rod Wiper
13	**	Gland Screw
14	1	Piston Rod
15	1	Cushion Sleeve
16	1	Stop Tube
17*	**	Piston Wear Ring
18*	1	Filled Teflon Seal with Buna Expander
19	1	Piston
20	1	Piston***
21*	1	Piston Wear Ring
22*	2	Piston Packing
23	1	Bronze Piston***

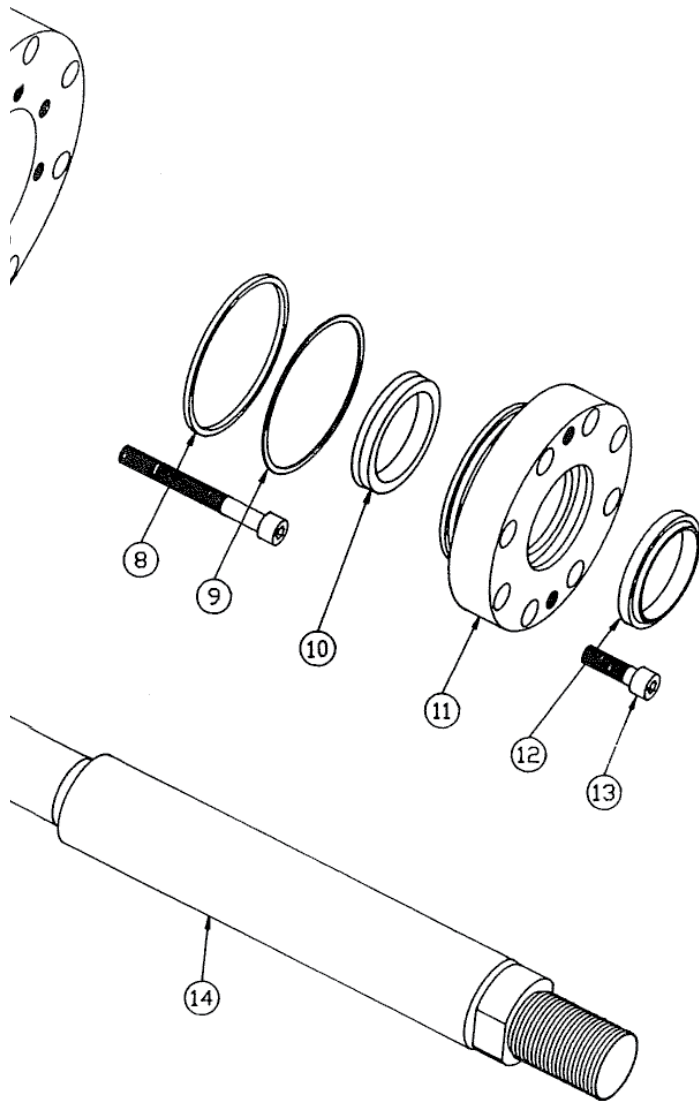

- * Recommended Spare Parts
- ** As Required
- *** Optional Parts

OTHER ACCESSORIES

Rod Boots

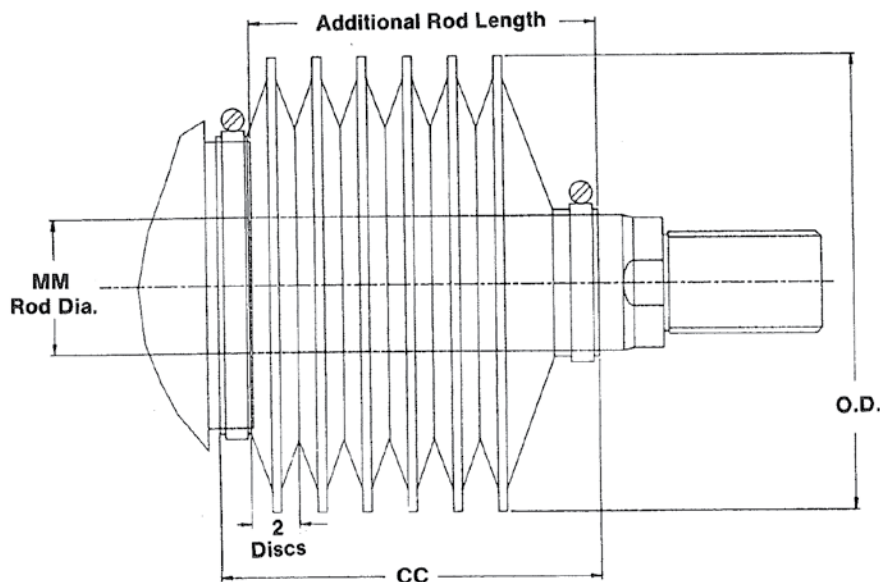

BORE	MM ROD DIA.	O.D.	BF	BORE	MM ROD DIA.	O.D.	BF	BORE	MM ROD DIA.	O.D.	BF	
2.00	1.00	4.75	1.25	7.00	2.50	10.00	3.06	10.00	3.50	12.00	3.56	
	1.38	5.25	1.38		3.00	10.00	2.81		4.00	12.00	3.25	
3.00	1.38	5.25	1.38		3.50	10.00	2.56		4.50	12.00	3.00	
	1.75	5.50	1.31		4.00	10.50	2.50		5.00	12.00	2.88	
	2.00	6.00	1.31		4.50	11.00	2.50		5.50	12.00	2.50	
4.00	1.75	6.00	1.56	8.00	5.00	11.00	2.38	12.00	7.00	13.25	2.50	
	2.00	6.00	1.31		3.00	11.00	3.31		4.00	12.00	3.25	
	2.50	6.50	1.31		3.50	11.00	3.06		4.50	12.00	3.00	
	5.00	2.50	7.00		1.56	4.00	11.00		2.75	5.00	12.00	2.88
3.00		7.00	1.31		4.50	11.00	2.50		5.50	12.00	2.50	
3.50		7.50	1.31	5.00	11.25	2.50	7.00	13.25	2.50			
6.00	2.50	9.00	2.56	9.00	3.50	11.00	3.06	14.00	5.50	14.25	3.62	
	3.00	9.00	2.31		4.00	11.00	2.75		7.00	14.25	3.00	
	3.50	9.00	2.06		4.50	11.00	2.50		8.00	14.25	2.50	
	7.00	4.00	10.50		2.50	5.00	11.25	2.50	16.00	5.50	14.25	3.62
		4.50	11.00		2.25	5.50	11.75	2.50		7.00	14.25	3.00
		5.00	11.75		2.25	6.00	11.75	2.25		8.00	14.25	2.50

ROD BOOT CALCULATIONS

Number of Discs = (2 x Total Stroke) ÷ BF (Raise result to next even whole number.)

CC (Length of Boot) = Number of Discs x .050 + 1.50.
(Raise result to nearest 1/8 inch.)

Additional Rod Length to accommodate Boot = CC - .75 Dim.

Air Bleeds

Air bleeds provide a means to remove all trapped air from hydraulic systems.

NOTE: Specify port position for bleed.

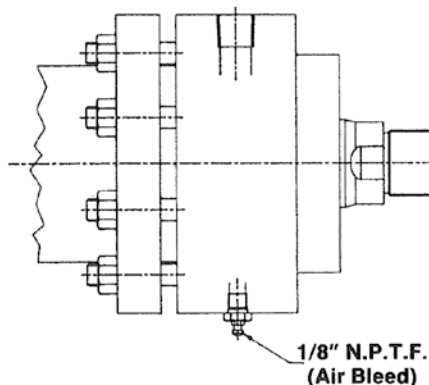

HOW TO ORDER

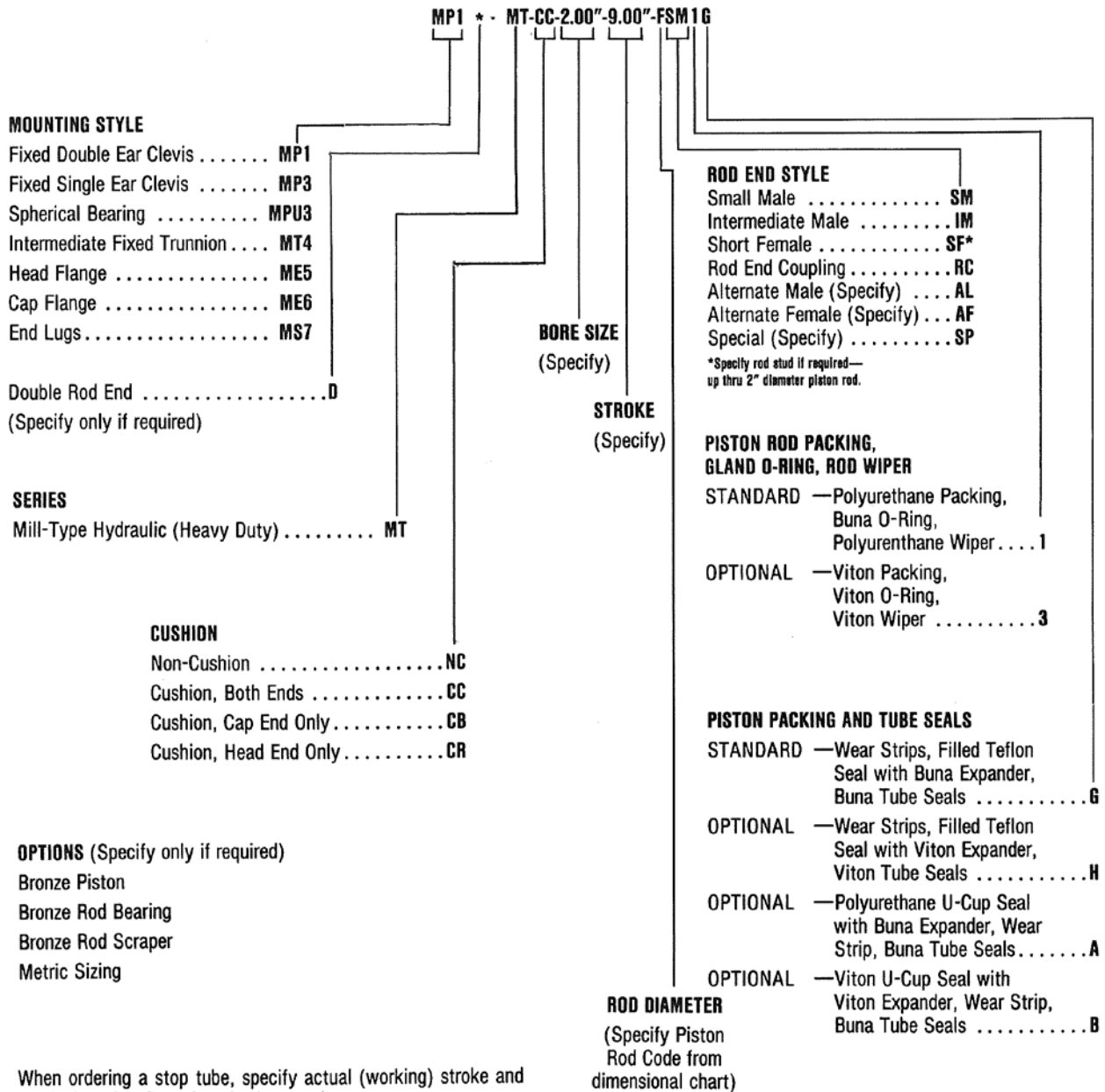

NOTE: Cushion needles furnished with viton seals.

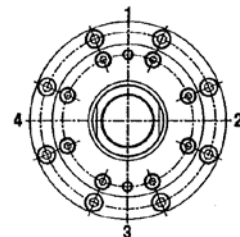

Port location: if other than position 1, must be specified.
Mounting accessories must be specified if required.